

THE GENERAL RADIO EXPERIMENTER

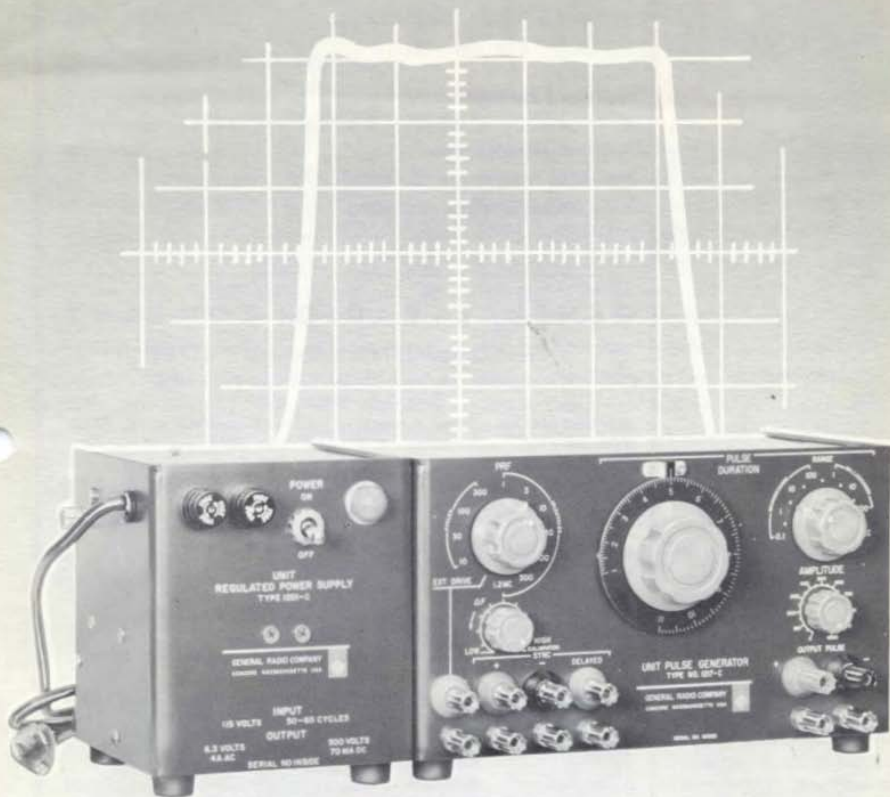

VOLUME 38 NUMBER 12

DECEMBER 1964



IMPROVED PERFORMANCE FROM

THE UNIT PULSE GENERATOR

IN THIS ISSUE

Microphone Reciprocity Calibrator
1-Mc Counter
Six-dial Decade Resistors



IET LABS, INC in the GenRad tradition
534 Main Street, Westbury, NY 11590

www.letlabs.com
TEL: (516) 334-5959 • (800) 899-8438 • FAX: (516) 334-5988

THE GENERAL RADIO

EXPERIMENTER



©1964—GENERAL RADIO COMPANY, WEST CONCORD, MASS., U.S.A.

Published Monthly by the General Radio Company

VOLUME 38 NUMBER 12 DECEMBER 1964

CONTENTS

	Page
Improved Performance from the Unit Pulse Generator	1
A Reciprocity Calibrator for the WE 640AA and Other Microphones	9
New One-Megacycle Counter	11
New 6-Dial Decade Resistors, 1Ω to $1.1111\text{ M}\Omega$ and 0.01Ω to $11.1111\text{ k}\Omega$	12

GENERAL RADIO COMPANY

West Concord, Massachusetts*, 01781

Telephone (Concord) 369-4400; (Boston) 646-7400
Area Code Number 617

METROPOLITAN NEW YORK: Broad Avenue at Linden, Ridgefield, N. J., 07657
Telephone—N. Y., 212 964-2722
N. J., 201 943-3140

SYRACUSE: Pickard Building, East Molloy Road,
Syracuse, N. Y., 13211
Telephone—315 454-9323

PHILADELPHIA: Fort Washington Industrial Park,
Fort Washington, Pennsylvania 19034
Telephone—215 646-8030

WASHINGTON* and BALTIMORE: 1142 Rockville Pike, Rockville, Md., 20852
Telephone—301 946-1600

ORLANDO: 113 East Colonial Drive, Orlando, Florida, 32801
Telephone—305 425-4671

CHICAGO: 6605 West North Avenue, Oak Park, Illinois, 60302
Telephone—312 848-9400

CLEVELAND: 5579 Pearl Road, Cleveland, Ohio, 44129
Telephone—216 886-0150

DALLAS: 2501-A West Mockingbird Lane, Dallas, Texas, 75235
Telephone—214 Fleetwood 7-4031

LOS ANGELES: 1000 North Seward St., Los Angeles, Cal., 90038
Telephone—213 469-6201

SAN FRANCISCO: 1186 Los Altos Ave., Los Altos, Cal., 94022
Telephone—415 948-8233

TORONTO: 99 Floral Parkway, Toronto 15, Ontario, Canada
Telephone—416 247-2171

MONTREAL: Office 395, 1255 Laird Blvd., Town of Mount Royal,
Quebec, Canada
Telephone—514 737-3673, -3674

*Repair services are available at these offices.

GENERAL RADIO COMPANY (Overseas), 8008 Zurich, Switzerland

GENERAL RADIO COMPANY (U.K.) LIMITED, Bourne End,
Buckinghamshire, England

Representatives in Principal Overseas Countries

The General Radio EXPERIMENTER is mailed without charge each month to engineers, scientists, technicians, and others interested in electronic techniques in measurement. When sending requests for subscriptions and address-change notices, please supply the following information: name, company address, type of business company is engaged in, and title or position of individual.



IET LABS, INC in the GenRad tradition
534 Main Street, Westbury, NY 11590

www.ietlabs.com
TEL: (516) 334-5959 • (800) 899-8438 • FAX: (516) 334-5988



IMPROVED PERFORMANCE FROM THE UNIT PULSE GENERATOR

One of our most popular Unit Instruments has long been the TYPE 1217 Unit Pulse Generator. The reason for its popularity is easy to see: It has consistently offered more prf range, pulse duration, and pulse amplitude per dollar than any other instrument of its type. Now, with the introduction of the TYPE 1217-C Unit Pulse Generator, specifications have been again improved significantly. The size remains the same, and the performance per dollar has again been sharply boosted, to a point where the Unit Pulse Generator is a model of value engineering.

For those who are familiar with

earlier models of the TYPE 1217, the major improvements in performance are: increased prf to 1.2 Mc/s (internal drive) and 2.4 Mc/s (external drive), and improved transition times to less than 10 nanoseconds with a more symmetrical pulse (see Figure 2).

For those who are unfamiliar with the Unit Pulse Generator, it is a compact, general-purpose pulse source, whose prf can be either internally controlled from 2.5 c/s to 1.2 Mc/s or externally controlled (the input circuits are then arranged as an aperiodic switching circuit) from dc to 2.4 Mc/s. Pulse duration is adjustable from 100 nanoseconds to 1.1 seconds, and ampli-



Figure 1. Type 1217-C Unit Pulse Generator with power supply.

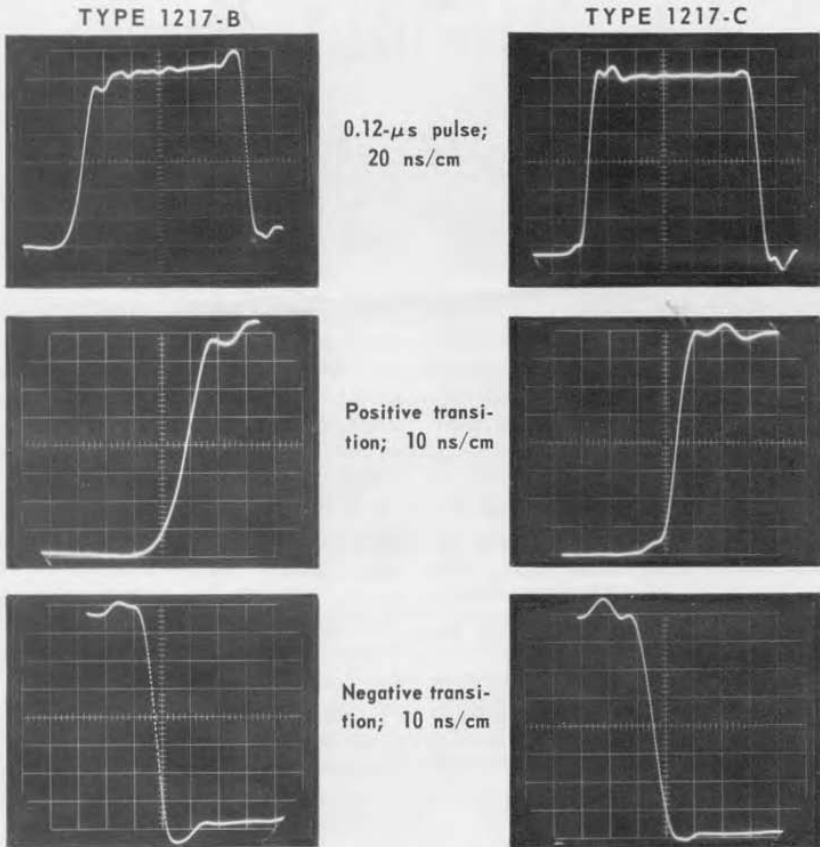

Figure 2. Oscillograms showing improvements in pulse symmetry and rise times in Type 1217-C over its predecessor.

tude of the 40-mA output pulse is also adjustable, up to 40 volts, peak (the AMPLITUDE control is actually calibrated in output impedance). Positive and negative prepulses and a delayed synchronizing pulse are also provided.

The Circuit

The circuit is basically that described in an earlier article on the TYPE 1217-B¹; a block diagram is shown in Figure 3.

A major design objective was economy, and this meant making every circuit component work all the time and to its full capability. The internal prf oscillator uses the same parts — rearranged by switching — that make up the input circuits in the external-drive mode. Another design feature was the com-

¹R. W. Frank, "More and Better Pulses from the Unit Pulse Generator," *General Radio Experimenter*, 36, 1-2, January-February 1962.

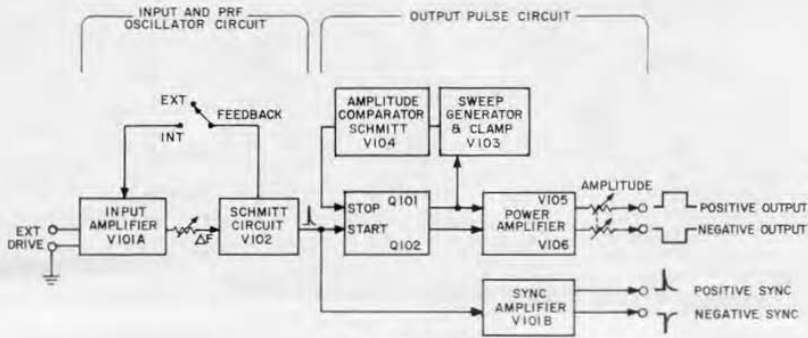

Figure 3. Block diagram.

mon-sense utilization of tubes and transistors to exploit the strong points of both.

The main components of the pulse generator are an input system, a pulse-timing circuit, and a power amplifier. Switched for internal control of prf, the input system is a stable, wide-frequency-range oscillator. Switched for external control, the circuit becomes an aperiodic trigger generator, made up of a dc amplifier and a Schmitt trigger. This circuit produces a single, brief, trigger pulse to initiate the action of the pulse-timing circuits once for each cycle of the input driving signal.

The output circuits include a set-reset bistable circuit, an rc ramp generator, and an amplitude comparator.

The circuit is similar to that used in all precision pulse generators and makes possible a relatively linear pulse-duration dial scale, low jitter, quick recovery time, and operation highly independent of supply-voltage changes and aging of the active devices. The warmup effects on prf and on pulse duration are shown in Figures 4 and 5.

The set-reset bistable circuit drives a pair of output tubes, which apply current to variable load resistors. The maximum value of these resistors is 1000 ohms, and the output current is over 40 mA; the maximum output voltage is therefore at least 40 volts.

The delayed (synchronizing) pulse corresponds to the late transition of the output pulse. This delayed pulse

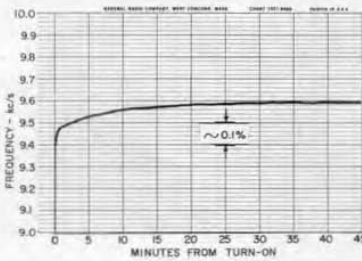

Figure 4. Warmup effects on pulse repetition frequency.

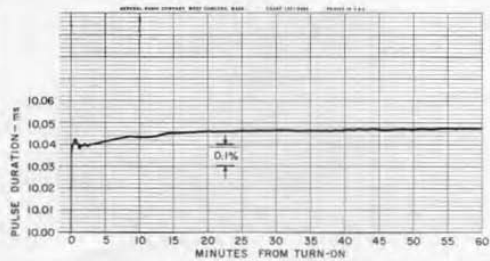
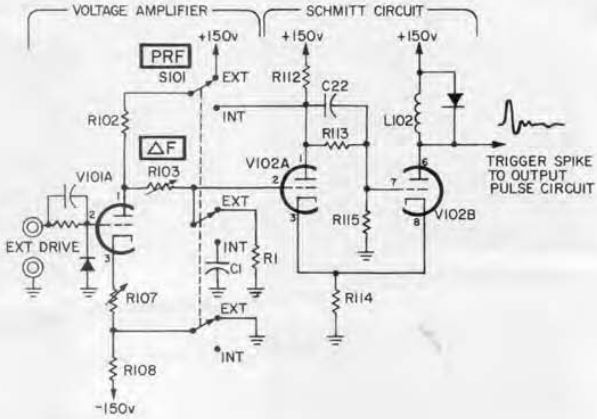

Figure 5. Warmup effects on pulse duration.

Figure 6. Schematic diagram of the input circuits. Switching at only three points converts a conventional Schmitt circuit, used with external drive, into a wide-range oscillator for internal prf control.



can be used to drive a second pulse generator; a pair of pulse generators therefore makes an excellent delayed-pulse generator, and three make a good double-pulse generator.

Output Pulse Waveform

The improvement in pulse transition time and symmetry comes about from the use of silicon transistors in place of germanium units. The voltage wave-

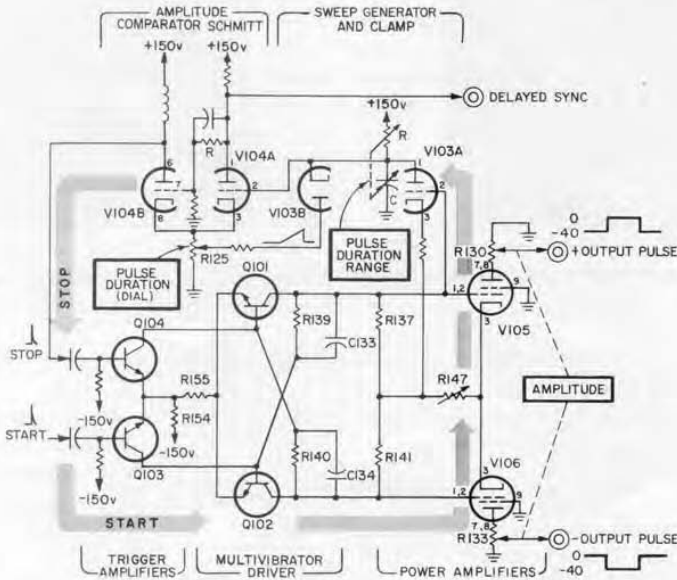

Figure 7. Schematic diagram of timing and output circuits. Transistors Q101 and Q102 are connected in a bistable circuit to control conduction of the output power tubes, V105 and V106. Such hybrid design exploits strong points of both tubes and transistors.



form at the output terminals depends on the termination. In Figure 2, the terminating resistance is 50 ohms. All transition times are less than 10 nanoseconds, and some overshoots occur. With no external loading, the very fast current transitions are applied to the 1000-ohm output potentiometer and an inherent stray capacitance of about 30 picofarads, and the voltage rise time is about 60 nanoseconds. Externally add-

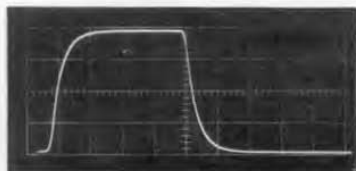

Figure 8. Oscilloscope showing effects of 12-pF probe on output pulse.

ed capacitance will increase this rise time by about 2 nanoseconds per picofarad. With this output configuration, no overshoot occurs, and the rise is purely exponential (see Figure 8).

Pulse DC Component

Notice, in Figure 7, that a dc component negative with respect to chassis ground appears on both the positive and negative pulses. When the amplitude control is fully open, the positive pulse rises from -40 volts to ground, and the negative pulse falls from ground to -40 volts. In other words, only the



negative output is truly "ground-based."

In many applications, the output will be capacitively coupled, and the dc component of the pulse will be of no consequence. Even when the dc component is important, however, it is rarely necessary that the positive pulse start precisely from chassis ground. In most cases it is desirable that the pulses make a transition from a potential other than ground. Adjustment at this potential is easy to accomplish. Figure 9 shows a simple method of voltage translation by which the dc level of either a positive or negative pulse can be adjusted as desired. A 400-volt laboratory power supply can thus translate the positive pulse so that it is completely above ground, with only a 10-percent reduction in output impedance. In most applications, no such power need be wasted for dc translation. Pulse amplifiers, "and" gates, etc. can be biased directly from the pulse gen-

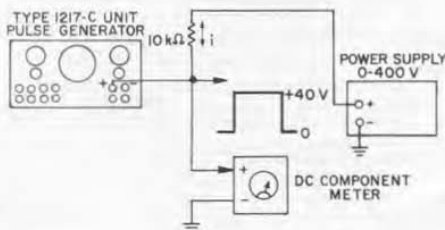

Figure 9. Connection of 400-V laboratory power supply and dc voltmeter for full translation of positive pulse. Any desired dc component can be obtained by adjustment of power-supply voltage. Dc component meter can be used to indicate duty ratio.



Figure 10. Control of transistor switching by Unit Pulse Generator. (top) NPN, normally on, goes off during pulse time. NPN, normally off, goes on during pulse time. PNP, normally off, goes on during pulse time. PNP, normally on, goes off during pulse time.

erator with low-power networks, as shown in Figure 10.

Uses

The TYPE 1217-C Unit Pulse Generator is a valuable tool in any laboratory where pulses are used. Its generalized characteristics and low price make it an ideal instrument for school-laboratory experiments in pulse techniques, as well as for work on radar, pulse communication, and computer systems.

Experience has also shown that the pulse generator is a useful source for measurements on transistor systems. It can operate saturated transistor switches, both npn and pnp, without coupling networks (see Figure 10). Since the pulse generator is direct-coupled, the solid-state switches can be operated over its full duration range.

— R. W. FRANK

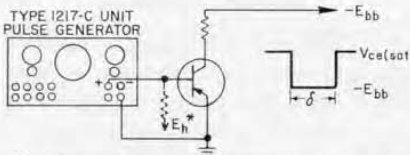
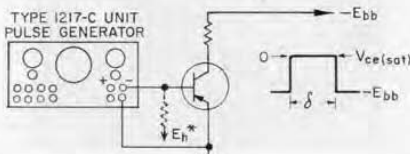
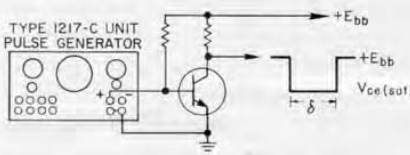
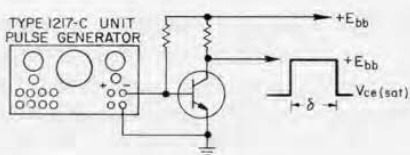

* HOLD-BACK BIAS MAY BE NECESSARY UNDER SOME HIGH TEMPERATURE CONDITIONS WHERE $I_{cho} R_o > V_{eb}$

SPECIFICATIONS

PULSE REPETITION FREQUENCY

Internally Generated: 2.5 c/s to 1.2 Mc/s, with calibrated points in a 1-3 sequence from 10 c/s to 300 kc/s, and 1.2 Mc/s, all $\pm 5\%$. Continuous coverage with an uncalibrated control.

Externally Controlled: Aperiodic, dc to 2.4 Mc/s with 1 V, rms, input (0.5 V at 1 Mc/s and lower); input impedance at 0.5 V, rms, approximately 100 k Ω shunted by 50 pF. Output pulse is started by negative-going input transition.

OUTPUT-PULSE CHARACTERISTICS

Duration: 100 ns to 1 s in 7 decade ranges, $\pm 5\%$ of reading or $\pm 2\%$ of full scale or ± 35 ns, whichever is greater.

Rise and Fall Times: Less than 10 ns into 50 or 100 Ω ; typically 60 ns + 2 ns/pF external load capacitance into 1 k Ω (40 V).

Voltage: Positive and negative 40-mA current pulses available simultaneously. Dc coupled, dc component negative with respect to ground. 40 V, peak, into 1-k Ω internal load impedance for both negative and positive pulses. Output

control marked in approximate output impedance.

Overshoot: Overshoot and noise in pulse, less than 10% of amplitude in correctly terminated measuring system.

Ramp-off: Less than 1%.

Synchronizing Pulses:

Pre-pulse: Positive and negative 8-V pulses of 150-ns duration. If positive sync terminal is shorted, negative pulse can be increased to 50 V. Sync-pulse source impedance:

- positive — approx 300 Ω ;
- negative — approx 1 k Ω .

Delayed Sync Pulse: Consists of a negative-going transition of approximately 5 V and 100-ns duration coincident with the late edge of the main pulse. Duration control reads time between prepulse and delayed sync pulse. This negative transition is immediately followed by a positive transition of approximately 5 V and 150 ns to reset the input circuits of a following pulse generator. (See oscillogram.)





Stability: Prf and pulse-duration jitter are dependent on power-supply ripple and regulation. With TYPE 1201 Power Supply, external-drive terminals short-circuited, prf jitter and pulse-duration jitter are each 0.01%. With TYPE 1203 Power Supply, they are 0.05% and 0.03%, respectively. (Jitter figures may vary

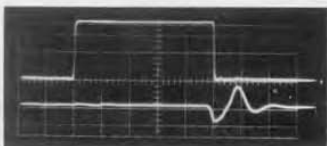

1- μ s pulse into 50 ohms with delayed sync pulse.

somewhat with range switch settings, magnetic fields, etc.)

GENERAL

Power Required: 300 V at 60 mA, 6.3 V at 3 A. Type 1203 Unit Power Supply or Type 1201 Unit Regulated Power Supply is recommended.

Accessories Available: TYPE 1217-P2 Single-Pulse Trigger, rack-adaptor panel for both generator and power supply, 19 by 7 in (485, 180 mm).

Cabinet: Unit-Instrument type.

Dimensions: Width 10 $\frac{3}{4}$ (15 with power supply), height 5 $\frac{3}{4}$, depth 6 $\frac{1}{2}$ inches (275, 150, 165 mm), over-all. Rack-adaptor panel, 19 by 7 inches (485, 180 mm).

Net Weight: 4 $\frac{1}{2}$ lb (2.1 kg).

Shipping Weight: 6 lb (2.8 kg).

Type		Price
1217-C	Unit Pulse Generator	\$275.00
1217-P2	Single-Pulse Trigger	25.00
1203-B	Unit Power Supply (for 115-volt supply)	55.00
1203-BQ18	Unit Power Supply (for 230-volt supply)	60.00
480-P4U3	Relay-Rack Adaptor Panel	12.00



A RECIPROCITY CALIBRATOR FOR THE WE 640AA AND OTHER MICROPHONES

Among the great time savers of recent invention was the GR TYPE 1559-A Microphone Reciprocity Calibrator¹, which replaced the tedium of a long, meticulous laboratory calibration with a minute or two of knob turning. The

¹Basil A. Bonk, "Absolute Calibration of PZT Microphones," *General Radio Experimenter*, 37, 4-5, April-May 1963.

original model, however, accepted only the General Radio measurement microphone, a limitation overcome by the new TYPE 1559-B Microphone Reciprocity Calibrator. Of especial importance is the fact that the new model will also calibrate the Western Electric 640AA-type microphone. Since the Na-



tional Bureau of Standards also reciprocity-calibrates this microphone, there is now a direct traceability link between NBS and the GR Reciprocity Calibrator.

The Reciprocity Calibrator is a portable, compact instrument containing the reference transducers and acoustic cavity necessary to perform the closed-coupler reciprocity calibration, together with an analog computer and switching mechanisms to reduce the entire procedure to a simple routine.

The TYPE 1559-B Microphone Reciprocity Calibrator will calibrate any microphone whose sensitivity is between -75 dB and -35 dB re 1 V/ μ bar, whose diameter is less than 1.125 inches and which is adaptable to use in a

closed coupler. GR TYPES 1560-P1, 1560-P3, and 1560-P4 microphones fit directly into the calibrator, and an adaptor is supplied for WE 640AA-type microphones. An adaptor is also available for calibration of GR TYPES 1551-P1L and 1551-P1H Condenser Microphone Systems.

Accessories required are an audio signal source and a detector (usually the instrument whose microphone is being calibrated). In the calibration of a microphone of the WE 640AA-type, a preamplifier and a source of polarizing voltage are also required; the preamplifier and power supply of the TYPE 1551-P1 Condenser Microphone Systems are satisfactory for this purpose.

SPECIFICATIONS

MICROPHONE CALIBRATOR

Range: Direct reading for microphone sensitivities between -35 dB and -75 dB re 1 V/ μ bar.

Accuracy:

Microphone Type	Accuracy	Frequency Range
WE 640AA and similar types	$\pm 0.2\text{dB} \pm 0.1\text{dBf}_{\text{kc}}$	20 c/s to 2.5 kc/s
	$\pm 0.7\text{dB}$	2.5 to 6 kc/s*
GR 1560-P3 and -P4	$\pm 0.2\text{dB} \pm 0.1\text{dBf}_{\text{kc}}$	20 c/s to 2.5 kc/s
	$\pm 0.7\text{dB}$	2.5 to 7 kc/s *
GR 1551-P1L	$\pm 0.2\text{dB} \pm 0.1\text{dBf}_{\text{kc}}$	20 c/s to 2.5 kc/s
	$\pm 0.7\text{dB}$	2.5 c/s to 5 kc/s

*To 8 kc/s with corrections.

PRECISION ACOUSTICAL SOURCE

Frequency Range: 20 c/s to 7 kc/s.

Output: 92 dB re 0.0002 μ bar for excitation of 50 V.

Accuracy: At 92 dB, ± 0.1 dB + error in determining microphone sensitivity.

SOUND-LEVEL CALIBRATOR

Frequency Range: 20 c/s to 2.5 kc/s.

Output: 92 dB re 0.0002 μ bar for excitation of 50 V.

Accuracy: ± 0.7 dB at standard atmospheric pressure.

GENERAL

Maximum Safe Input Voltage: 50 V behind 600 Ω .

Accessories Required: Generator and detector. Generator to supply 5 V or more into a 2000-pF load, and 2.5 V or more into a 600- Ω load. Lower voltage can be used, with a resultant lowering of signal-to-ambient-noise ratio. The TYPE 1304-B Beat-Frequency Audio Generator, the TYPE 1210-C Unit R-C Oscillator, and the TYPE 1310-A Audio Oscillator are recommended. The TYPE 1551-B or -C Sound-Level Meter is recommended for the detector.

Accessories Supplied: TYPE 274-NP Patch Cord and an extension cable for connection to generator and detector; and adaptors for reciprocity and comparison calibration of the Western Electric 640AA and equivalent microphones.

Cabinet: Flip-Tilt; relay-rack model also is available.

Dimensions: Portable model, case closed: width 10, height 8, depth 7 $\frac{1}{2}$ in (255, 205, 190 mm), over-all; rack model: panel 19 by 10 $\frac{1}{2}$ in (485, 270 mm), depth behind panel 5 in (130 mm).

Net Weight: Portable model, 13 lb (6 kg); rack model, 14 lb (6.5 kg).

Shipping Weight: Portable model, 22 lb (10 kg); rack model, 29 lb (13.5 kg).

Type		Price
1559-B	Microphone Reciprocity Calibrator, Portable Model	\$525.00
1559-B	Microphone Reciprocity Calibrator, Rack Model	525.00

US Patent No. 2,966,257.





NEW ONE-MEGACYCLE COUNTER



A new 1-Mc counter has joined the ranks of GR's fast-growing line of digital frequency equipment. The TYPE 1150-BH Digital Frequency Meter is similar to the 400-kc TYPE 1150-B¹ in all respects except frequency range. In other words, it is a trim (3½ inches high in a relay rack), economical, solid-state counter with crisp, bright, incandescent readout.

Counting time can be set to 0.01, 0.1, 1, or 10 seconds, and display time

is adjustable in 7 discrete steps from 0.16 to 10.24 seconds, or infinity. Other panel controls include a trigger level adjustment, a mode switch (to select frequency measurement, self-check, or count), a reset button, and a toggle switch for manual control of counting time and for counting times that are multiples of 10 seconds.

The new counter is also available as the TYPE 1150-BPH, equipped for direct connection to either the TYPE 1137-A Data Printer or the TYPE 1136-A Digital-to-Analog Converter.

¹R.W. Frank, "400-kc Solid-State Counter," *General Radio Experimenter*, 38, 8, August 1964.

SPECIFICATIONS

Frequency Range: Dc to 1 Mc/s.

Sensitivity: 1 V, p-to-p, to 400 kc/s, 2 V, p-to-p, to 1 Mc/s.

Counting Time: 10 ms to 10 seconds, extendible by multiplier switch.

Accuracy: ±1 count ± crystal-oscillator stability.

Display: 5-digit in-line register, incandescent-lamp operated.

Display Time: 0.16, 0.32, 0.64, 1.28, 2.56, 5.12, or 10.24 seconds, or infinity.

Input Impedance: 1 MΩ shunted by 100 pF.

Input Trigger Level: Adequate to permit triggering on zero crossings of signals twice minimum amplitude and on brief pulses of either polarity.

Crystal-Oscillator Stability:

Short-Term: Better than 0.5 ppm.

Cycling: Less than counter resolution.

Temperature Effects: Less than 2½ ppm for rise of 0 to 50°C ambient.

Warmup: Within 1 ppm after 15 minutes.

Aging: Less than 1 ppm/wk after 4 weeks, decreasing thereafter.

Crystal Frequency Accuracy: Within 10 ppm when shipped. Frequency adjustment provided.

Power Required: 105 to 125 or 210 to 250 V, 50 to 60 c/s, 40 W.

Accessories Supplied: TYPE CAP-22 Power Cord, eight replacement incandescent lamps, spare fuses.

Accessories Available: TYPE 1136-A Digital-to-Analog Converter and TYPE 1137-A Data Printer (operate from output of Type 1150-BPH model only).

Cabinet: Rack-bench.

Dimensions: Bench model, width 19, height 3⅞, depth 12½ in (485 by 99 by 320 mm), over-all; rack model, panel 19 by 3½ in (485 by 90 mm), depth behind panel 12¾ in (325 mm).

Net Weight: 19 lb (9 kg).

Shipping Weight: 22 lb (10 kg).

Type		Price
1150-BHM	Digital Frequency Meter, Bench Model	\$1095.00
1150-BHR	Digital Frequency Meter, Rack Model	1095.00
1150-BPHM	Digital Frequency Meter, with output for printer or D/A converter, Bench Model	1150.00
1150-BPHR	Digital Frequency Meter, with output for printer or D/A converter, Rack Model	1150.00



NEW 6-DIAL DECADE RESISTORS

Two new six-dial models have been added to the GR line of TYPE 1432 Decade Resistors, one with steps of one ohm, the other with steps of 0.01 ohm. Housed in the laboratory-bench-style aluminum cabinets that are characteristic of the TYPE 1432 series, these new decade boxes have 11-position rotary switches with silver-overlaid contact studs on the low-resistance decades to ensure stability of resistance. All decades have a silver contact in the zero position in order that the zero resistance of the box be both low and constant. The GR jack-top binding posts accept wire leads, banana plugs, alligator clips, spade terminals, and telephone tips. Three binding posts are used, two for the resistor terminals, the third grounded to the aluminum panel. A removable shorting link is included to permit optional grounding of one side of the resistor.

1 Ω to 1.1111 M Ω
and
0.01 Ω to 11.1111 k Ω

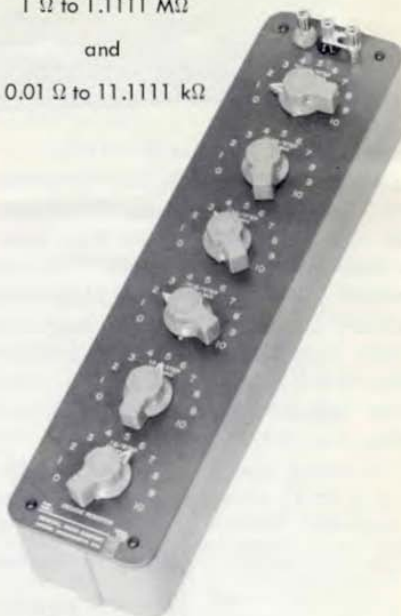

SPECIFICATIONS

Resistance: See price table
Accuracy: See table (right). Resistors are adjusted for incremental as well as total value. Accuracy, as always, is included in the standard General Radio two-year warranty.
Cabinet: Laboratory-bench type.
Dimensions: Width 4 $\frac{5}{16}$, height 4 $\frac{3}{4}$, length 18 $\frac{1}{4}$ in (110, 125, 465 mm).
Net Weight: 7 $\frac{1}{2}$ lb (3.5 kg).
Shipping Weight: 9 lb (4.1 kg).

Resistance per Step	Accuracy	Max Current for 40° C Rise
100 k Ω	0.05%	2.3 mA
10 k Ω	0.05%	7 mA
1 k Ω	0.05%	32 mA
100 Ω	0.05%	80 mA
10 Ω	0.05%	250 mA
1 Ω	0.15%	800 mA
0.1 Ω	0.5%	1.6 A
0.01 Ω	2%	4 A

Type	Maximum	Per Step	Price
1432-B Decade Resistor	1,111,110 Ω	1 Ω	\$185.00
1432-W Decade Resistor	11,111.1 Ω	0.01 Ω	158.00

GENERAL RADIO COMPANY

extends to all *Experimenter* readers
its best wishes for a
Happy and Prosperous 1965

