

## PRS-300 SERIES

**Programmable  
Decade Resistance Substituters  
(IEEE-488.2, Ethernet and USB)  
Operation Manual**





---

**IET LABS, INC.**

[www.ietlabs.com](http://www.ietlabs.com)  
TEL: (516) 334-5959 • (800) 899-8438 • FAX: (516) 334-5988

## PRS-300 SERIES

### Programmable Decade Resistance Substituters (IEEE-488.2, Ethernet and USB) Operation Manual



Copyright © 2017 IET Labs, Inc.

PRS-300 IM / June 2018



**IET LABS, INC.**

www.ietlabs.com  
TEL: (516) 334-5959 • (800) 899-8438 • FAX: (516) 334-5988

◆ PRECISION INSTRUMENTS FOR TEST AND MEASUREMENT ◆



---

**IET LABS, INC.**

www.ietlabs.com  
TEL: (516) 334-5959 • (800) 899-8438 • FAX: (516) 334-5988

## **WARRANTY**

We warrant that this product is free from defects in material and workmanship and, when properly used, will perform in accordance with applicable IET specifications. If within one year after original shipment, it is found not to meet this standard, it will be repaired or, at the option of IET, replaced at no charge when returned to IET. Changes in this product not approved by IET or application of voltages or currents greater than those allowed by the specifications shall void this warranty. IET shall not be liable for any indirect, special, or consequential damages, even if notice has been given to the possibility of such damages.

**THIS WARRANTY IS IN LIEU OF ALL OTHER WARRANTIES, EXPRESSED OR IMPLIED, INCLUDING BUT NOT LIMITED TO, ANY IMPLIED WARRANTY OF MERCHANTABILITY OR FITNESS FOR ANY PARTICULAR PURPOSE.**



## **WARNING**



OBSERVE ALL SAFETY RULES  
WHEN WORKING WITH HIGH VOLTAGES OR LINE VOLTAGES.

**Dangerous voltages may be present inside this instrument. Do not open the case  
Refer servicing to qualified personnel**

### **HIGH VOLTAGES MAY BE PRESENT AT THE TERMINALS OF THIS INSTRUMENT**

WHENEVER HAZARDOUS VOLTAGES (> 45 V) ARE USED, TAKE ALL MEASURES TO  
AVOID ACCIDENTAL CONTACT WITH ANY LIVE COMPONENTS.

USE MAXIMUM INSULATION AND MINIMIZE THE USE OF BARE  
CONDUCTORS WHEN USING THIS INSTRUMENT.

**Use extreme caution when working with bare conductors or bus bars.**

WHEN WORKING WITH HIGH VOLTAGES, POST WARNING SIGNS AND  
KEEP UNREQUIRED PERSONNEL SAFELY AWAY.



## **CAUTION**



DO NOT APPLY ANY VOLTAGES OR CURRENTS TO THE TERMINALS OF THIS  
INSTRUMENT IN EXCESS OF THE MAXIMUM LIMITS INDICATED ON  
THE FRONT PANEL OR THE OPERATING GUIDE LABEL.

# SAFETY SUMMARY

The following general safety precautions must be observed during all phases of operation, service, and repair of this instrument. Failure to comply with these precautions or with specific WARNINGS elsewhere in this manual may impair the protection provided by the equipment. Such noncompliance would also violate safety standards of design, manufacture, and intended use of the instrument.

IET Labs assumes no liability for the customer's failure to comply with these precautions.

The PRS-300 complies with INSTALLATION CATEGORY I as well as POLLUTION DEGREE 2 in IEC61010-1.

If an instrument is marked CAT I (IEC Measurement Category I), or it is not marked with a measurement category, its measurement terminals must not be connected to line-voltage mains.

The PRS-300 is an indoor use product.

## DANGEROUS PROCEDURE WARNINGS

Comply with all WARNINGS - Procedures throughout in this manual prevent you from potential hazard. These instructions contained in the warnings must be followed.

### BEFORE APPLYING POWER

Verify that all safety precautions are taken. Make all connections to the instrument before applying power. Note the instrument's external markings described under "Safety Symbols".

### GROUND THE INSTRUMENT

This is a Safety Class I instrument. To minimize shock hazard, the instrument chassis and cabinet must be connected to an electrical ground. The power terminal and the power cable must meet International Electrotechnical Commission (IEC) safety standards.



- DO NOT Operate in an Explosive Atmosphere
- Do not operate the instrument in the presence of inflammable gasses or fumes
- Operation of any electrical instrument in such an environment clearly constitutes a safety hazard
- Use Caution around live circuits
- Operators must not remove instrument covers
- Component replacement and internal adjustments must be made by qualified maintenance personnel only
- DO NOT substitute parts or modify the instrument

To avoid the danger of introducing additional hazards, do not install substitute parts or perform unauthorized modifications to the instrument.

Return the instrument to an IET Labs for service and repair to ensure that safety features are maintained in operational condition.

# Safety Symbols

General definitions of safety symbols used on the instrument or in manuals are listed below.



Caution symbol: the product is marked with this symbol when it is necessary for the user to refer to the instruction manual.



Hazardous voltage symbol: the product is marked with this symbol when high voltage maybe present on the product and an electrical shock hazard can exist.



Indicates the grounding protect terminal, which is used to prevent electric shock from the leakage on chassis. The ground terminal must connect to earth before using the product



Direct current.



Alternating current.



Frame or chassis terminal. A connection to the frame (chassis) of the equipment which normally includes all exposed metal structures.



On supply.



Off supply.



Hot surface. Avoid contact. Surfaces are hot and may cause personal injury if touched.

## Disposal



Waste Electrical and Electronic Equipment (WEEE) Directive 2002/96/EC

This product complies with the WEEE Directive (2002/96/EC) marking requirements.

The affixed label indicates that you must not discard this electrical/ electronic product in domestic household waste.

Product Category: With reference to the equipment types in the WEEE directive Annex 1, this product is classified as a “Monitoring and Control instrumentation” product.

Do not dispose of electrical appliances as unsorted municipal waste, use separate collection facilities.

Contact your local government for information regarding the collection systems available. If electrical appliances are disposed of in landfills or dumps, hazardous substances can leak into the groundwater and get into the food chain, damaging your health and well-being.

When replacing old appliances with new one, the retailer is legally obligated to take back your old appliances for disposal.



# CONTENTS

<b>WARRANTY</b> .....	<b>i</b>
<b>WARNING</b> .....	<b>ii</b>
<b>CAUTION</b> .....	<b>ii</b>
<b>CONTENTS</b> .....	<b>iii</b>
<b>FIGURES</b> .....	<b>iv</b>
<b>TABLES</b> .....	<b>iv</b>
<b>Chapter 1: INTRODUCTION</b> .....	<b>1</b>
<b>Chapter 2: SPECIFICATIONS</b> .....	<b>3</b>
2.1 Specifications .....	3
2.2 General Specifications and Stability .....	4
2.2 Typical Label.....	5
<b>Chapter 3: OPERATION</b> .....	<b>6</b>
3.1 Initial inspection and setup .....	6
3.2 Connection .....	6
3.2.1 General Considerations .....	6
3.2.2 Electrical Considerations.....	6
3.3 Condensed Operating Instructions .....	6
3.4 Menu Structure.....	7
3.4.1 Main Menu .....	8
3.4.2 Setting a Resistance Value.....	8
3.4.3 Menu Button.....	8
3.4.4 Standard Values Screen .....	8
3.4.5 TABLE Key.....	9
3.4.6 Increment INCR Key.....	9
3.4.7 OPEN Key.....	9
3.4.8 STO,RCL Keys.....	10
3.4.9 VOLT Key .....	10
3.4.10 2 and 4 Wire Connections .....	10
3.4.11 Thermal emf Considerations .....	10
3.4.12 Environmental Conditions.....	11
3.4.13 Remote Operation.....	11
<b>Chapter 4: USB Interface</b> .....	<b>12</b>
4.1 Introduction.....	12
4.2 Capabilities .....	12
4.3 USB Operation.....	12
<b>Chapter 5: ETHERNET INTERFACE OPTION</b> .....	<b>14</b>
5.1 Ethernet Programming .....	14
5.2 Network Setup .....	14
5.3 Ethernet Test Keyboard.....	14
5.4 Network Configuration .....	15

5.5 Web Browser Configuration.....	15
5.6 VXI Configuration Utility.....	17
5.7 Resetting Default Network Settings.....	19
5.8 PRS Programming .....	19
<b>Chapter 6: IEEE INTERFACE OPTION.....</b>	<b>20</b>
6.1 Introduction.....	20
6.2 Capabilities .....	20
6.3 Address Switch and Communications Settings.....	20
6.4 IEEE Option Operation.....	20
<b>Chapter 7: PROGRAMMING.....</b>	<b>22</b>
7.1 Introduction .....	22
<b>Chapter 8: MAINTENANCE .....</b>	<b>23</b>
8.1 Verification of Performance .....	23
8.1.1 Calibration Interval.....	23
8.1.2 General Considerations .....	23
8.1.3 Calibration Procedure .....	23
8.1.4 Adjustment of Internal Resistors .....	23
<b>Chapter 9: PRS-DMM Self Adjusting Software .....</b>	<b>25</b>
9.1 PRS-DMM Self Adjusting Software .....	25
9.1.1 PRS-DMM Self Adjusting Software Overview.....	25
9.1.2 General Requirements.....	25
9.1.3 Software Installation .....	25
9.1.3 Connection Between DMM and PRS-300 .....	25
9.1.3 PC Connection Between DMM and PRS-300.....	25
9.2 PRS-DMM Main Screen .....	26
9.2.1 PRS-DMM Main Screen Operation.....	26
9.3 PRS-DMM Settings .....	26
9.3.1 PRS-DMM Settings Screen .....	26
9.3.2 PRS-DMM Settings .....	26
9.3.3 Meter Settings .....	27
9.3.4 Adjust PRS .....	27
9.3.4 PRS-DMM Speed.....	28
<b>APPENDIX A: SCPI COMMAND REFERENCE.....</b>	<b>29</b>
<b>APPENDIX B: IEEE.2 COMMON COMMANDS.....</b>	<b>33</b>

# Chapter 1

## INTRODUCTION

The PRS-300 (Figure 1.1) is a high precision manual and programmable decade substituter. The PRS-300 series provide direct resistance substitution as well as RTD (Resistance Temperature Detector) simulation.

The PRS-300 substituter is a precision resistance source with excellent characteristics of stability, temperature coefficient, and power coefficient. These features combined with a low virtually constant “zero resistance” make for very versatile instruments.

Operation is both local using convenient display and keypad and remote standard USB or optional Ethernet, and IEEE-488.2 interfaces. An RS-232 interface is also available upon request.

The PRS-300 employs very low resistance, low thermal emf relays with gold-clad silver-alloy contacts. A special design keeps contact resistance to a minimum. The gold plating keeps the silver contacts from becoming tarnished when unused, or when only low currents are passed through them. This is most often the case when only minute test currents are drawn by digital multimeters and other test instruments. Contact resistance remains low and repeatable.

High-quality gold-plated tellurium-copper

five-way binding posts serve to minimize the thermal emf effects, which would produce errors in dc resistance measurements.

With a resolution as low as  $1 \mu\Omega$  and a maximum available resistance of  $20 \text{ M}\Omega$ , the PRS-300 may be used for exacting precision measurement applications requiring high accuracy, good stability, and low zero resistance.

The PRS-300 is suited for automatic and manual calibration and testing, simulation of RTD’s, programmable loads, and many other laboratory and industrial applications.

The PRS Series may be rack mounted to serve as components in measurement and control systems.

The PRS-300 (Figure 1.1) is part of the PRS family of high precision manual and programmable decade substituters. This series



*Figure 1.1: High Precision Programmable Decade Resistance Substituter*

offers a wide choice of ranges, power, voltage, and accuracies for a wide variety of design and production applications.

The PRS-300 uses a microcontroller design to enhance the ease of use and calibration. It provides direct resistance substitution as well as RTD (Resistance Temperature Detector) simulation. It allows for higher precision and tighter tolerances.

The PRS-300 is a precision resistance source with excellent characteristics of accuracy, stability, temperature coefficient, and power coefficient. It is direct reading without the need to subtract “zero resistance.”

The PRS-300 offers the option of true 4-wire Kelvin measurement for calibration applications and 2-wire mode for use in series as a substitute resistor and for RTD applications. The front panel display indicates the mode selected: 2-wire or 4-wire.

There are two pre-programmed RTD resistance tables, and others may be added by the user. The controller allows for other convenient programmed features.

The unique design makes adjustment of the PRS-300 for calibration semiautomatic. An

internal calibration routine guides the user to perform measurements using *only* a precision ohmmeter and enter the measured values into the PRS-300. No other standards are required.

IET Labs offers the PRS-DMM Self Adjusting Software which works with the PRS-300 and Fluke 8508A or Keysight 3458A to automate this adjustment process and eliminate the need for a technician to manual enter the resistance values manually into the PRS-300

## Chapter 2 SPECIFICATIONS

For convenience to the user, the pertinent specifications are given in an OPERATING GUIDE, shown typically in Figure 2.1, affixed to the case of the instrument.

### 2.1 Specifications

#### User interface:

Numeric keypad to enter resistance value with digital display.

**Accuracy:**  $\pm(70 \text{ ppm} + 1 \text{ m}\Omega)$  2 and 4 Terminal at  $23^\circ\text{C} \pm 5^\circ\text{C}$  Also see section 2.2

**Minimum setting:**  $0.1 \Omega$

**Resolution:**  $1 \mu\Omega$  or 6 digits

**Range:**  $0.1 \Omega - 20 \text{ M}\Omega$

**Stability:** See section 2.2

**Thermal emf:**  $< 15 \mu\text{V}$

**Maximum Load:** 2 A, 200 V (peak), 0.5 W whichever applies first

**Resistors:** Precision wire-wound and metal foil

**TC of Resistors:**  $< 1 \text{ ppm}/^\circ\text{C}$  for R4 and above

#### RTD Tables:

9 RTD tables can be entered into memory to allow user selection of temperature and the correct value of resistance will automatically be programmed.

PT-100 and PT-1000 tables for both Fahrenheit and Celsius are pre-programmed into memory locations 1 to 4.

#### Adjustment:

Automatic adjustment procedure utilizing a high precision DMM eliminates the requirement for manual trimming of resistors.

#### AC Frequency Response:

Residual Capacitance Terminals to GND:  $< 850 \text{ pF}$

Resistance	Typical ac/dc difference @ 1 kHz
0.1 $\Omega$ - 10 k $\Omega$	$< 100 \text{ ppm}$
10 - 100 k $\Omega$	$< 200 \text{ ppm}$
100 k $\Omega$ - 1 M $\Omega$	$< 1\%$
1 - 20 M $\Omega$	$< 20\%$

#### Terminals:

Four low-emf, gold-plated, tellurium-copper 5-way binding posts are used for **HI** and **LO** terminal pairs for **CURRENT** and **SENSE**. **GND** binding post is connected to the case, to the chassis ground and to the earth ground.

**Switching time:** 15 ms Max for relay switch time between values, typically  $< 1 \text{ ms}$ .

$< 20 \text{ ms}$  to interpret command and switch via ieee.488 interface

#### Power requirements:

90 - 264 Vac , 47 - 63 Hz. 30 Watts Max.

#### Environmental conditions:

**Operating:**  $10^\circ\text{C}$  to  $40^\circ\text{C}$ ;  $< 80\% \text{ RH}$

**Storage:**  $-40^\circ\text{C}$  to  $70^\circ\text{C}$

Note: exposure to humidity  $> 60\%$  for extended periods of time can cause the resistors to drift some of which is reversible. See 2.2 for more information

#### Dimensions:

Bench model: 43 cm W x 8.9 cm H x 33 cm D (17" x 3.5" x 13") *in front of panel:* 3.8 cm (1.5").

#### Weight:

Bench model: 5.5 kg (12 lb); weight specifications are nominal.

#### Remote Control:

**USB:** USB Type B connector standard on rear panel

#### Remote Control Options:

##### IEEE:

GPIB standard 24 pin connector, conforms to IEEE-488.2; SCPI 1994.0 command set; Hardware or software configurable addressing range of 1 to 30.

##### Ethernet:

IEEE 802.3 compliant, Speeds 10 BaseT (10 Mb/s) and 100 BaseT (100 Mb/s), IP Address Static or DHCP, Factory setting 192.168.0.254 static

## 2.2 General Specifications and Stability

### Warmup:

This unit utilizes custom designed low thermal emf relays for high stability and low-level signal applications. This thermal voltage is nominally less than 15  $\mu\text{V}$  under laboratory conditions. Please note that a change in this thermal emf will give a false drift in resistance as measured by a dc ohmmeter, since the ohmmeter will interpret this emf as an effective resistance. The worst case such effective drift after warm-up is less than  $\pm 25$  ppm, primarily due to stabilization of this emf at the relay contacts as settings are changed.

Unit should be allowed to stabilize for one hour. For maximum stability, allow unit to warm-up over two hours.

### Recommended Calibration Interval:

Typical calibration interval 12 months. Adjustment can easily be accomplished using IET's PRS-DMM software. Adjusting the PRS-300 can improve accuracy.

### Environmental:



This product complies with the WEEE Directive (2002/96/EC) marking requirements. The affixed label indicates that you must not discard this electrical/electronic product in domestic household waste.

Product Category: With reference to the equipment types in the WEEE Directive Annex I, this product is classed as a "Monitoring and Control instrumentation" product.

### Effects of Humidity:

Exposure to humidity  $>60\%$  for a periods of weeks can cause the resistors to drift some of which is reversible. It is recommended that the PRS-300 be stored at humidities less than 50% to minimize this.

More information of the effects of humidity on foil resistors can be found at: [http://www.vishaypg.com/docs/63516/VFR\\_TN110.pdf](http://www.vishaypg.com/docs/63516/VFR_TN110.pdf)

### Short-term Stability:

The PRS-300 was tested for extended periods of time. Based upon this testing the following stability information was determined. These specifications apply for the PRS-300 in 4 terminal mode with shorting links removed and without switching to another value.

### Typical short-term stability without switching:

$$< \pm(4 \text{ ppm} + 100 \mu\Omega) / 10 \text{ minutes}$$

### Typical 24 hr. Accuracy after Adjustment:

After performing an adjustment per 8.1.4 using a Fluke 8508A and then performing a calibration verification per 8.1.3 within 24 hours the typical accuracy is:

$$\pm(30 \text{ ppm} + 300 \mu\Omega) \text{ for values less than } 1 \text{ M}\Omega$$

$$\pm 60 \text{ ppm for values of } 1 \text{ M}\Omega \text{ and higher}$$

See graph below for actual performance with 6 digit resolution across resistance range.

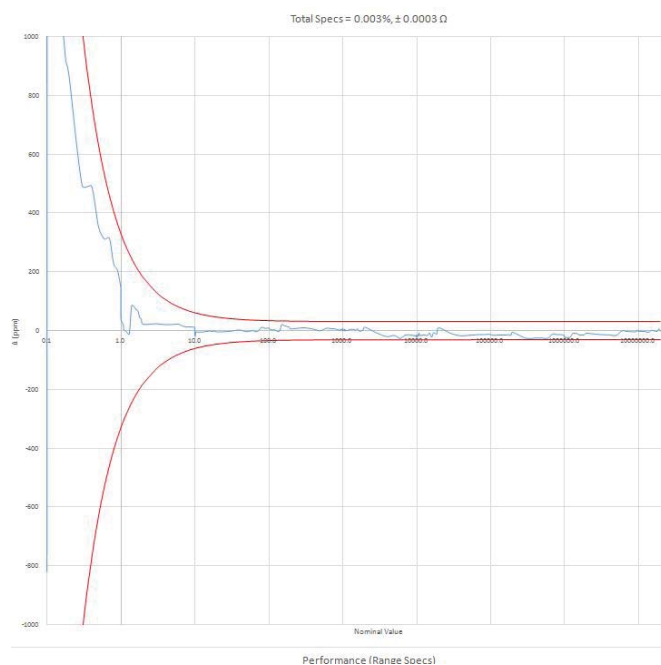

## PRS-300 PROGRAMMABLE DECADE RESISTANCE SUBSTITUTER

CONSULT INSTRUCTION MANUAL FOR PROPER INSTRUMENT OPERATION

**Accuracy:**  $\pm(0.007\% + 1 \text{ m}\Omega)$  2 and 4 Terminal at 23°C  $\pm 5^\circ\text{C}$

**Minimum setting:** 0.1  $\Omega$

**Resolution:** 1  $\mu\Omega$  or 6 digits

**Range:** 0.1  $\Omega$ - 20 M $\Omega$

**Thermal emf:** < 15  $\mu\text{V}$

**Maximum Load:** 2 A, 200 V (peak), 0.5 W whichever applies first

**Resistors:** Precision wire-wound and metal foil

**RTD Tables:**

9 RTD tables can be entered into memory to allow user selection of temperature and the correct value of resistance will automatically be programmed. PT-100 and PT-1000 tables for both Fahrenheit and Celsius are programmed into memory locations 1 to 4.

**Adjustment:**

Automatic adjustment procedure utilizing a high precision DMM eliminates the requirement for manual trimming of resistors.

**Terminals:**

Four low-emf, gold-plated, tellurium-copper 5-way binding posts are used for **HI** and **LO** terminal pairs for **CURRENT** and **SENSE**. **GND** binding post is connected to the case, to the chassis ground and to the earth ground.

**Switching time:** <1 second per change

**Power requirements:**

90 - 264 Vac , 47 - 63 Hz. 30 Watts Max.

**Remote Control:**

**USB:** Standard USB Type B connector on rear panel, uses FTDI driver

**Remote Control Options:**

**IEEE:** GPIB standard 24 pin connector, conforms to IEEE-488.2; SCPI 1994.0 command set; Hardware or software configurable addressing range of 1 to 30.

**Ethernet:** IEEE 802.3 compliant, Speeds 10 BaseT (10 Mb/s) and 100 BaseT (100 Mb/s), IP Address Static or DHCP, Factory setting 192.168.0.254 static

**MODEL:** PRS-300

**SN:** B1-17341127

**WARNING**

Observe all safety rules when working with high voltages or line voltages. Connect the (GND) terminal to earth ground in order to maintain the case at a safe voltage. Whenever hazardous voltages (>45 V) are used, take all measures to avoid accidental contact with any live components: a) Use maximum insulation and minimize the use of bare conductors. b) Remove power when adjusting switches. c) Post warning signs and keep personnel safely away.



**IET LABS, INC.**  
CAGE CODE: 62015

• Long Island, New York  
• Tel: (516) 334-5959 • Email: info@ietlabs.com



[www.ietlabs.com](http://www.ietlabs.com)

PRS-300 Nov. 2016

*FIGURE 2.1 Typical OPERATING GUIDE Affixed to Unit  
(Please see label affixed to your unit)*





## Chapter 3 OPERATION

### 3.1 Initial inspection and setup

This instrument was tested and carefully inspected before shipment. It should be in proper electrical and mechanical order upon receipt.

An **OPERATING GUIDE** is attached to the case of the instrument to provide ready reference to specifications.

Mount the unit in a standard 19" rack if the rack mount option is specified.

### 3.2 Connection

#### 3.2.1 General Considerations

The PRS-300 Decade Resistor utilizes a 5-terminal connection. The binding posts are standard laboratory type and readily accept banana plugs, spade lugs, alligator clips, and bare wire. Binding posts are located on the front panel of the instrument unless specifically ordered with a Rear Output option.

The Kelvin terminals consisting of a **CURRENT** and a **SENSE** pair, each labeled **HI** and **LO**. These minimize contact resistance.

**4 Wire connection** the gold shorting links must be removed on the binding posts of the PRS-300 and the PRS-300 set to 4 Wire.

**2 Wire connection** the gold shorting links must be used on the binding posts of the PRS-300 and the PRS-300 set to 2 Wire.

See section 3.4.10 for more information

The **GND** terminal on all models is connected to the case and to earth and chassis grounds. This may be used as a shield terminal.

#### 3.2.2 Electrical Considerations

The performance of the PRS-300 is directly affected by the quality of the connection to the system under test. This is particularly true with the precision series models having higher-accuracy and/or lower-impedance decades.

For optimum performance, contact resistance should be kept to a minimum by using the most substantial mating connection possible, and by assuring that the connection is well secured to the binding posts.

### 3.3 Condensed Operating Instructions

1. Turn on the PRS-300 ON using POWER SWITCH
2. Select a desired resistance value in one of the following ways:
  - a) Enter a value using the number keys, then press **ENTER**.
  - b) Press a Quick Value key (**A – B**) to display a user-defined value or a factory default value.

Default values are: **A**: 10 kΩ | **B**: 100 kΩ

- c) Press **RCL** then a number key (**0 – 9**) to display a user-defined value or a factory default value.

Default values are: **0** - 100 Ω | **1** - 1 kΩ | **2** - 2 kΩ

- 3.  To prevent possible damage to the PRS-300, set the maximum applied voltage by pressing **VOLT**, entering the voltage on the keypad, then pressing **ENTER**. (Default: 0.5 V)

*The firmware sets the minimum selectable resistance value so that the power does not exceed 1 W. To ensure that the whole range of resistances is selectable, VOLT setting must be  $\leq 1$  V.*

*Rmin is limited to  $> V^2$ , where V is the VOLT setting.*

- 4. Select 2-wire or 4-wire mode by pressing the **MENU** button, selecting **CONFIGURE**, pressing the “2” will change between 2-wire and 4-wire modes

In 2-wire mode shorting links must be installed across high and low terminal pairs.

In 4-wire remove the shorting links.

- 5. Connect to the circuit or device under test.



To isolate the PRS-300 from the application, press **OPEN** to open the circuit. To close the circuit, press **OPEN** again.

### 3.4 Menu Structure





The main table below show menu structure of the PRS-300 and basic function of each button and menu selection.

Key	Description	Function
-----	-------------	----------

#### Basic operation

<b>enter</b>	enter button	Sets resistance value
<b>0-9, 000/(-)</b>	Used to enter numerical values.	To select desired numerical value, press value as required. (-) is used with tables for negative temperature
	Deletes the last character from the display.	To delete the last character, press  .

#### Options

<b>MENU</b>	Displays the following submenu: 1. STANDARD VALUES 1: 1% STD VALUES 2: 5% STD VALUES 3: 10% STD VALUES 4: RATIONOMETRIC 2. CONFIGURE 1: LCD CONTRAST 2: 2W / 4W MODE 3. CALIBRATE 4. VERSION	Press <b>MENU</b> to select one of the following: 1. STANDARD VALUES - selects increments for UP  and DOWN  keys 2. CONFIGURE - allows user to adjust display contrast and change between 2-wire and 4-wire modes 3. CALIBRATE - see Section 8 4. VERSION - Displays current firmware version and release date.
<b>INCR</b>	Selects the increments for the UP  and DOWN  keys Default value: Ratiometric (0.8% of displayed value)	To adjust increments: 1. Press <b>INCR</b> . 2. Enter desired increment value on the keypad. 3. Press <b>ENTER</b> to save.

#### Storing and recalling resistance values

<b>STO</b>	Stores a resistance value in memory locations A-D and 0-9.	To store a value, press <b>STO</b> and then press the desired location button A-D or 0-9.
<b>A, B</b>	Recalls a stored resistance value. Default values: <b>A</b> : 10 kΩ <b>B</b> : 100 kΩ	To change stored values: 1. Enter a resistance value 2. Press <b>STO</b> and then <b>A, B</b>
<b>RCL</b>	Recalls a stored resistance value from memory location 0-9.	To recall a stored value, press <b>RCL</b> , then press the desired location button (0-9)

#### Limiting Current

<b>VOLT</b>	Sets voltage to limit the current in order to protect the PRS-300 from possible damage. Default value: 0.5 V	To adjust voltage: 1. Press <b>VOLT</b> . 2. Enter desired voltage on the keypad. 3. Press <b>ENTER</b> to save.
-------------	---	---

#### Electrical Isolation

<b>OPEN</b>	Isolates the connection terminals by establishing an open circuit.	To open the circuit, press <b>OPEN</b> . To close, press <b>OPEN</b> again.
-------------	--	---

#### Option: Simulating RTD's and transducers

<b>TABLE</b>	Loads up to 9 stored data tables for simulating RTD's or transducers.	To select the desired table, press <b>TABLE</b> to cycle through the three options.
--------------	---	---

### 3.4.1 Main Display

The main display shows the resistance value in ohms or temperature value if tables are used. The main display also shows if the unit is configured for **4W** (4-wire mode) or **2W** (2-wire mode) in the upper left corner of the display.



Figure 3-1 Main Display showing 4-Wire

See section 3.2.3 for more information on 2-wire and 4-wire connections.

### 3.4.2 Setting a Resistance Value

To set a resistance value use the numeric keypad to enter the value followed by the **ENTER** button. The **000** button can be used to increase the resistance value by a factor of 1000.

The **UP ▲** and **DOWN ▼** keys can also be used to increment or decrement the resistance value. See 3.4.6 **INCR** Key for more information.

### 3.4.3 Menu Button

Pressing the **MENU** button will show four selections. See Figure 3-2



Figure 3-2 Menu Screen

Press the numerical value 1 to 4 on the keypad for the desired selection.

Press the **MENU** button to cancel and return to previous screen at anytime.

### 3.4.4 Standard Values Screen

There are 4 selections available in the **STANDARD VALUES** menu. The operation of the standard values allows the PRS-300 to be used as an automated resistance carousel with built-in EIA “preferred value” resistance tables of 1% (E96), 5% (E24), 10% (E12) increments or **RATIOMETRIC** user specified increment.



Figure 3-3 Standard Values Menu

Press the numerical value 1 to 4 on the keypad for the desired standard values.

Resistors are available in a number of standard ranges, often called ‘preferred values’ These ranges, or series, are set out by the Electronic Industries Association (EIA), and common values are E12, E24, E48, and E96. The number after the ‘E’ denotes the number of values the series contains per decade.

The series are logarithmic and are derived from the resistor tolerance; resistors with a tighter tolerance can have more values in the series that won’t overlap one another. The series are sometimes referred to by the tolerance, the two being related as follows:

- E12: 10% tolerance
- E24: 5% tolerance
- E48: 2% tolerance
- E96: 1% tolerance

When a **STANDARD VALUE** is selected on the PRS-300 pressing the **UP** or **DOWN** arrows will increment the resistance value to the

next “preferred” resistance value.

RATIOMETRIC allows a custom tolerance value to be entered by the user. The default value is 0.8% but can be set to the required value in %.

### 3.4.5 Tables Key

Pressing the **TABLE** key allows use of tables. There are 9 tables that can be selected. The first 4 tables, 1 to 4, are defined as PT-100 C, PT-100 F, PT-1000 C and PT-1000 F where C is degrees Celcius and F is degrees Fahrenheit.

Press **TABLE** key and then a number key 0 through 9 followed by the **ENTER** key will select a table. Table 0 is defined as no table is used and resistance is shown.

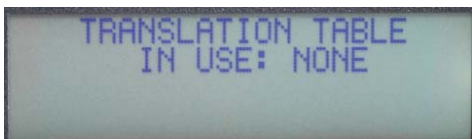

Figure 3-4 No translation Table

Press the numerical value 1 to 9 on the keypad for the desired table to be used. For example pressing **TABLE** key, then “1” and **ENTER** key will select use of the PT-100 C table as shown in Figure 3-5

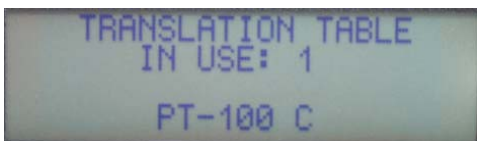

Figure 3-5 Table 1 PT-100 C

Once the table is selected the display will change showing temperature on top and resistance on bottom. Any value entered via front panel or remotely will be assumed to be a table value rather than a resistance value. For example if 0.25 is entered then the screen will

look like Figure 3-5 showing temperature on top line and resistance on the bottom line.

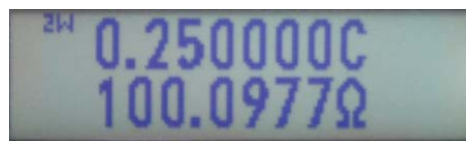

Figure 3-5 PR-100 C set to 0.25 °C

For negative temperatures press the 000/(-) key prior to entering the value.

If a value is not listed in the table and is entered using the numeric keypad or selected using the **UP** and **DOWN** keys interpolation is used between the two closest table values.

Custom tables can be entered in locations 5 to 9 by using the USB interface and remote **CONIG:TABLE** commands. See Appendix B for more information.

### 3.4.6 Increment INCR Key

The **INCR** key allows entry of a numeric value. The numeric value representing the step or increment size the **UP ▲** and **DOWN ▼** keys use.

For example pressing **INCR** key and then 10 would result in the displayed value being incremented or decremented 10 Ω for each time the **UP** or **DOWN** key is pressed.

**INCR** can also be used for tables in the same way so that the operator can press the **UP** or **DOWN** key and increment or decrement the displayed value in °C or °F.

### 3.4.7 OPEN Key

The **OPEN** key opens all relays in the PRS-300 resulting in high resistance at the resistance terminals. The display will shown **OPEN Ω**. Pressing the **OPEN** key again will cause the resistance to return to the previous set value.

For short enter lowest value of 0.1 Ω using keypad or remote.

### 3.4.8 STO, RCL Keys

The **STO** and **RCL** key are used to store user defined values into memory. Press **STO** key followed by 0 to 9 in the numeric keypad stores the currently shown resistance value into that memory location.

Press **RCL** key followed by 0 to 9 in the numeric keypad recalls the resistance value saved into memory to the currently displayed value.

### 3.4.9 VOLT Key

The **VOLT** key should normally be set to 0.5 V which allows us of the full resistance range of the PRS-300. Pressing the **VOLT** key followed by a numeric value representing the maximum voltage being used in the application will limit the lowest resistance that can be entered to prevent damage to the PRS-300.

The limited is based upon a maximum of 1 W being applied to the resistors. Note that 0.5 W is the maximum recommended and operation at 1 W can cause the internal resistors to drift beyond specification.

### 3.4.10 2 and 4 Wire Kelvin Lead Connections

**2-wire** or **4-wire** operation can be selected from by pressing the **MENU** button, selecting **CONFIGURE**, pressing the “2” will change between 2-wire and 4-wire modes.

The use of 4W mode with Kelvin leads minimize the effects of contact resistance and gives best performance. In 4-wire remove the shorting links from the high and low terminal pairs.

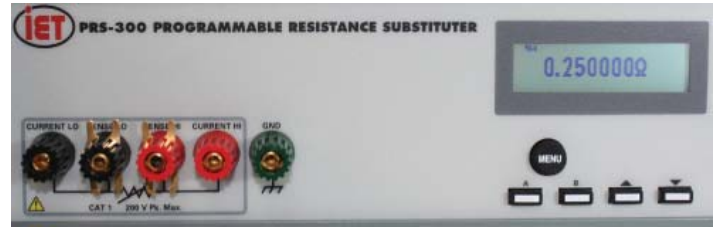

Figure 3-6 4-Terminal shorting links not connected

2W mode should be used when connecting to a 2 wire device or if the PRS-300 will be used as a standard 2-terminal resistor such as RTD simulation. In 2-wire mode shorting links must be installed across high and low terminal pairs.



Figure 3-7 Two terminal with shorting links

### 3.4.11 Thermal emf Considerations

The PRS Series uses high-quality, low-emf components. Thermal emf is primarily attributable to the temperature difference between the leads of the relay and the contacts when temperature is applied to the coil. This emf is of the order of 5  $\mu\text{V}$  per relay, but is not usually additive. The typical worst case is <15  $\mu\text{V}$ .

If the effect of tens of microvolts is significant to your application, connect to the instrument with low-thermal-emf materials only. Copper wire and copper alloys are recommended; brass and steel should be avoided. Tinned copper and solder are acceptable.

This emf will *not* be reflected if an ac measurement instrument is employed, and can be eliminated by using a meter with “True Ohm” capability. In other cases, the emf may represent a very small component of a dc resistance measurement.

### 3.5 Environmental Conditions

The PRS is built, calibrated and intended for use in a laboratory environment with a nominal ambient temperature near 23°C. The accuracy of the unit may be affected when operated in non-laboratory environments. Always allow the instrument to stabilize at room temperature after unpacking or relocating the instrument. Humidity should be maintained at laboratory conditions.

### 3.6 Remote Operation

When the PRS is in **REMOTE** with front panel locked out an REM indication will be shown in the top right of the display.



## Chapter 4 USB INTERFACE

### 4.1 Introduction

The standard USB connection is via a standard USB B female connector located on the rear panel. This can be connected to a PC via a standard USB 2.0 A Male to B Male Cable.



Figure 4-1 USB 2.0 A Male to B Male Cable

The SCPI standard provides a tree like series of standard commands for programmable instruments so that similar instruments by different manufacturers can be controlled by the same program.

### 4.2 Capabilities

The USB interface provides remote control over all functions except **POWER**.

### 4.3 USB Operation

The USB uses the command set outlined in Appendix B. Data should be terminated with LF line feed.

Normally when the PRS-300 is connected to a computer using the USB port, Windows 7 and higher will search for the correct driver and as long as the computer is connected to the internet the driver should automatically be installed.

### 4.3.1 Standard USB Interface

The standard USB interface uses a standard FTDI chip set. Drivers can be found from ftdi or the link below.

<http://www.ietlabs.com/prs-300-programmable-decade-resistor.html>

Data Rates and Formats

Baud Rate: 9600 baud

Date bits 8

Parity none

Stop bits 1

### 4.3.2 Optional IEEE Interface with High Speed USB Interface

The USB interface that comes with the optional ieee interface uses an MCP2200 chip set. This is a higher speed USB interface than the standard USB interface.

Drivers can be found at the link below.

<http://www.ietlabs.com/prs-300-ieee-ethernet.html>

Data Rates and Formats

Baud Rate: 9600 baud

Date bits 8

Parity none

Stop bits 1





## Chapter 5

# ETHERNET INTERFACE OPTION

### 5.1 Ethernet Programming

PRS units, with Ethernet interface option, come with Ethernet remote programming capability accessed through the RJ45 LAN connector. The connector is a RJ45 industry-standard connector found on the rear panel. The PRS's Ethernet connection is based upon the ICS Ethernet/GPIB/USB to Serial Interface Card. More information can be found at [www.icselect.com](http://www.icselect.com) on the 9006 Ethernet/GPIB/USB to Serial Interface Card.

#### Ethernet Protocols

The PRS supports Raw Socket and the VXI-11 protocol which makes it easy to control from a PC or over the company network.

Raw socket lets you telnet to it and is best used with direct PC to instrument applications. VXI-11 operates over Sun RPC and is a more secure protocol that mimics GPIB control of an instrument and provides secure communication over a company network or over the Internet.

#### Raw Socket Operation

The PRS is always ready for a telnet connection. When connected, the PRS outputs its IDN message to confirm the connection.

All raw socket messages are terminated with a linefeed. Carriage returns and ignored. A backspace character causes the prior character to be deleted. Communication timeout is two minutes and it is recommended that the client issue a Space-BS sequence on an occasional basis, less than the timeout, to reset the timeout counter.

### VXI-11 Background

VXI-11 is a communication standard developed in conjunction with the VISA Specification. The specification defines a VXI-11.3 interface like the PRS as an instrument which can be controlled in Windows systems by programs that make VISA or SICL library calls and in UNIX/LINUX or similar operating system with RPC calls. The VXI-11 specification provides an RPCL (Remote Procedure Call Library) that can be used by virtually any operating system to control the PRS. Microsoft's RPC is not ONC compliant and cannot be used with a VXI-11.3 device like the PRS. An VXI-11.3 interface like the PRS will operate in an LXI system and it supports LXI's 'VXI Discovery Method'.

### 5.2 Network Setup

The PRS includes an internal WebServer with HTML web pages that can be accessed by a web browser from any computer. The web pages let the user quickly change the PRS network settings. The default IP address is 192.168.1.253 static.

### 5.3 Ethernet Test Keyboard

To assist the user in setup and communication the VXI-11kybd program can be used which includes defined RPC calls to change the PRS network settings. VXI-11 Keyboard Control Program provides interactive control of VXI-11 instruments from the computer keyboard without having to write a program. The VXI-11 Keyboard program is the

ideal utility program for configuring and testing the PRS or any VXI-11 compatible instrument. Use the VXI-11kybd program to exercise the interface or to try out commands before using them in a program. The VXI-11kybd program can be found on the PRS product page at [www.ietlabs.com](http://www.ietlabs.com)

### Versatile Programming

The PRS can be easily controlled by several programming techniques and languages because it is a VXI-11.3 instrument. If you program with LabVIEW, National Instruments' VISA supports VXI-11.3 instruments like the PRS. NI's Measurement and Automation Explorer treats the PRS as a TCP/IP compliant device. Agilent's VISA library supports VXI-11.3 instruments and the Agilent Connection Manager sees the PRS as a TCP/IP instrument.

If you are a Visual Basic, VB.Net or C/C++ programmer, you can write your program to call Agilent's or National Instruments' VISA or Agilent's SICL library in the Windows environment.

If you use LINUX or any other flavor of UNIX like SunOS, IBM-AIX, HP-UX, or Apple's OS X, you can communicate with the PRS through RPC over TCP/IP. RPC (or Remote Procedure Calls) provides an invisible communication medium for the developer. The VXI-11 specification provides an RPCL (Remote Procedure Call Library) that can be used by virtually any operating system to control the PRS.

If you program with Java then you can write a PRS control program that can be easily moved to many different operating systems.

The Java jGpibEnet project on SourceForge was developed using an ICS 8065 Controller similar to the PRS Controller.

### 5.4 Network Configuration

This paragraph configures the 9006 card in the PRS for operation on your network. The board's digital interface is configured later by sending

commands as outlined in Appendix A.

When shipped, the boards are configured with default settings outlined in Table 4-1 Default Settings.

Command	Function	Factory Setting
IP Mode	Static or DHCP Mode	Static
IP Address	0.0.0.0 to 255.255.255.255.0	192.168.1.254
Net Mask	0.0.0.0 to 255.255.255.255.0	255.255.255.0
COMM Timeout	Sets socket timeout	120 sec.
Auto Disconnect	Aborts socket if link count goes to 0	Off

Table 4-1 Default Settings

Review the Table with your network administrator and decide on which settings, if any, that need to be changed. Table 4-1 provides detailed information about each network setting to help you with your decisions. The minimum change is to set a static IP address so your PC can communicate with the board.

The network configuration can be changed and the board's MAC Address can be read with a web browser, by running ICS's VXI-11 Configuration Utility on a WIN32 or WIN98 PC. ,

### 5.5 Web Browser Configuration Method

This method uses a standard browser such as Firefox, Internet Explorer or Safari to view and change the current network settings.

1. Temporarily disconnect the computer from the company network. Connect the PRS and computer running the browser using a standard Ethernet Cables to a hub or switch. Temporarily disconnect the local network connection to avoid network conflicts until the board is configured.

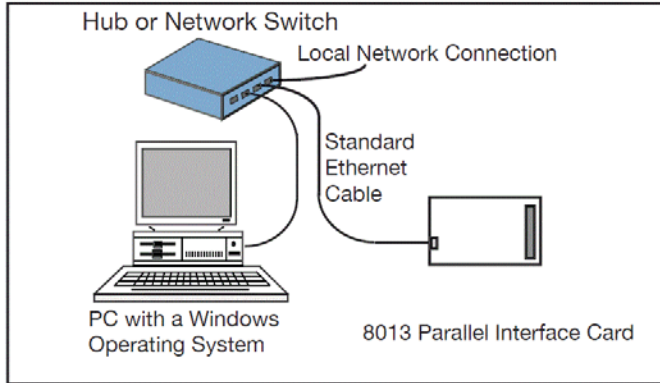

Figure 4-1 9006 Connected to the local hub

An alternate connection is to use an Ethernet Crossover Cable to connect the computer directly to the PRS for initial configuration. This will eliminate any potential network conflicts while configuring the PRS.

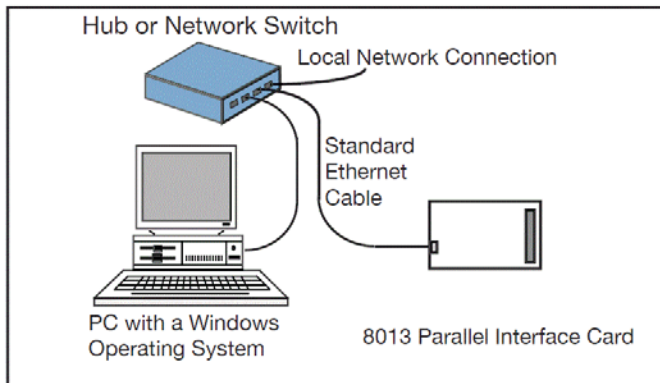

Figure 4-2 9006 Connected to the local hub

2. Apply power to the PRS. Set the Remote local switch to Remote.

3. Check your computer's network settings to be sure its IP address is in the 192.168.1.xxx range so it can communicate with the PRS Ethernet board's default IP address. If it is not, it must be set before proceeding. Use the values shown below. For Windows PCs, right-click on My Network Places and click on Properties. Right-click on Local Area Connection and click Properties. Highlight Internet Protocol (TCP/IP) and click Properties. If your PC's IP address is in

a different range, record the current settings and temporarily set the following network values:

Check 'Use the following IP Address'  
 IP Address 192.168.1.254  
 Subnet mask 255.255.255.0

4. Open the browser and enter the default IP address of 192.168.1.254 for new units (or your last set address for older units) in the browser address window.

5. A Welcome Page similar to the one shown Figure 4-3 should appear in your browser.

6. If you want to change any of the settings, press the 'Update Configuration' button. A Configuration Page similar to the one shown in Figure 4-4 should appear in your browser.

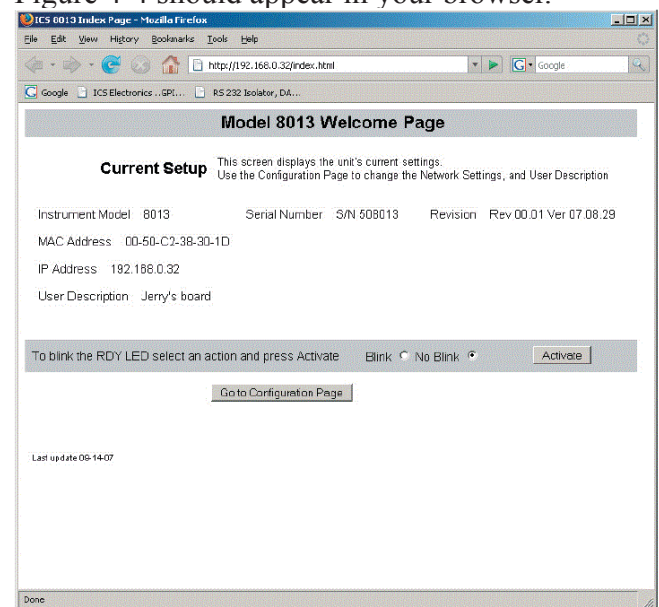

Figure 4-3 9006 Welcome Page

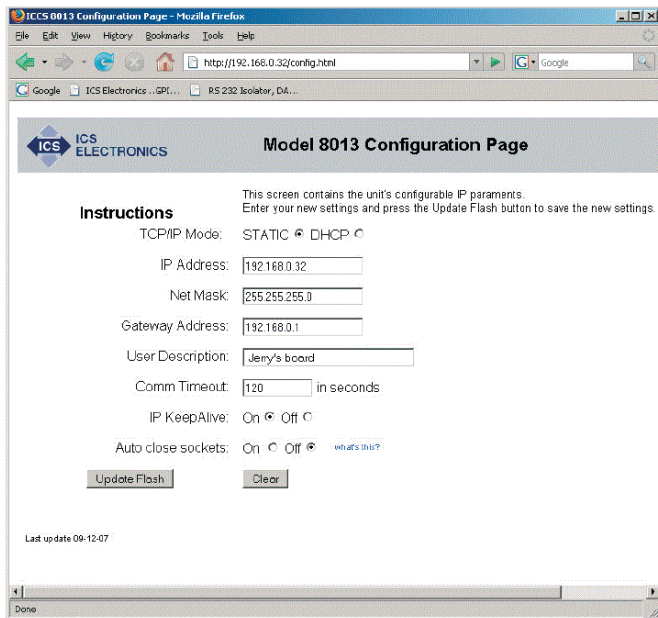

Figure 4-4 9006 Configuration Page

7. Enter the new settings as desired. If you select DHCP for the TCP/IP Mode, the page blanks out the IP, Net and Gateway addresses as they will be supplied by your DHCP server. Check the entered values carefully as the unit’s webserver does minimal error checking. Press the ‘Update Flash’ button when done. A Confirmation Page similar to the one shown in Figure 4-5 will appear in your browser.

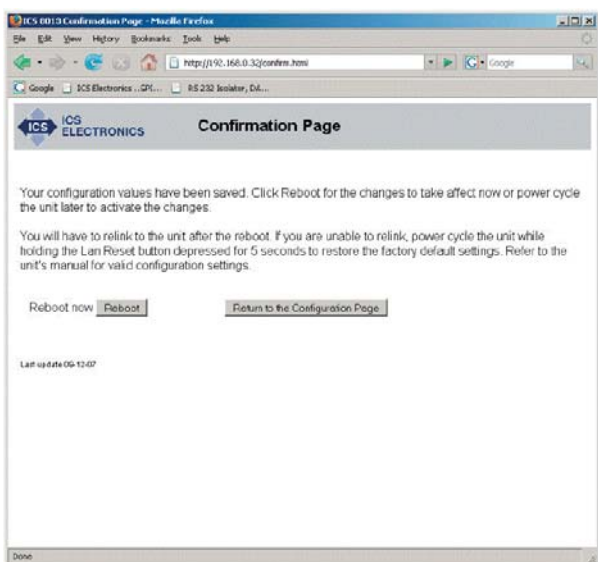

Figure 4-5 9006 Confirmation Page

8. Your new settings have been saved in the board’s flash memory. You have to reboot the unit or power cycle it for the changes to take affect. Press the ‘Reboot’ button to reboot the unit now or the ‘Return to the Configuration Page’ button to revisit the new settings.

### 5.6 VXI-11 Configuration Utility Method

The VXI-11 Configuration Utility program is called ‘VXI11\_config.exe’ and runs in any WIN32 PC with Windows 98, Me, 2K, XP, Vista, 7 and Server 2003 operating systems. The VXI11\_config.exe program can be found on the PRS product page at [www.ietlabs.com](http://www.ietlabs.com).

The VXI11\_config program can be run from the CD or can be installed onto your hard disk and run from the installation directory.

VXI11\_config.exe is a Visual Basic program and requires that either Microsoft’s Visual Studio 6 or VBruntime6 be installed on your PC to run.

1. Connect the board directly to the WIN32 PC that will be running the Configuration Utility. Disconnect the PC from the company network and use the supplied Ethernet Crossover Cable to connect the PC to the board as shown in Figure 4-6. This will eliminate any potential network conflicts while configuring the board.

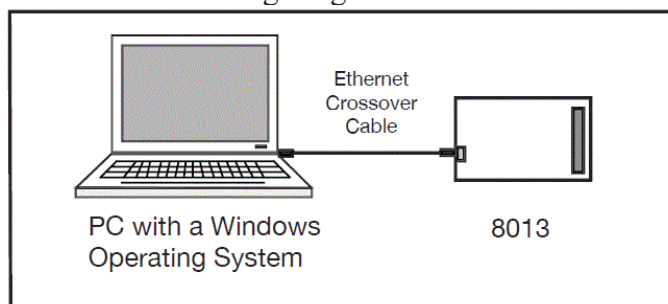

Figure 4-6 9006 Connected to PC with a Crossover Cable

Alternately, use a standard Ethernet patch cable



to connect the 9006 to the same hub or switch that the PC running the Configuration Utility is connected to as shown in Figure 4-7. Temporarily disconnect the local network connection to avoid network conflicts until the board is configured.

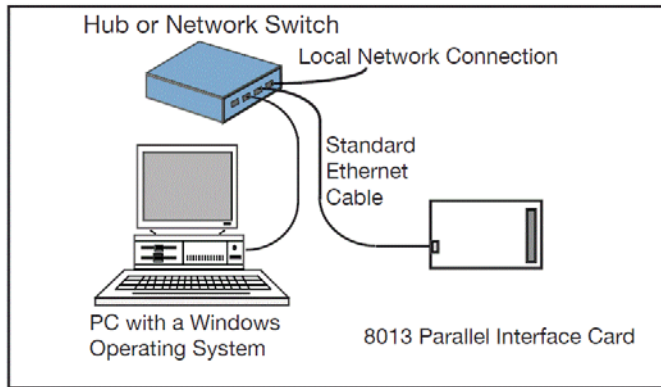

Figure 4-7 9006 Connected to the local hub

2. Apply power to the board

3. Check your PC's network settings to be sure its IP address is in the 192.168.1.xxx range so it can communicate with the board's default IP address. To check, right-click on My Network Places and click on Properties. Right-click on Local Area Connection and click Properties. Highlight Internet Protocol (TCP/IP) and click Properties. If your PC's IP address is in a different range, record the current settings and temporarily set the following network values:

Check 'Use the following IP Address'  
 IP Address 192.168.1.254  
 Subnet mask 255.255.255.0

4. Run the VXI11\_config program. The Configuration Utility opens a window as shown in Figure 4-8. Initially only the Find Server, Help and Exit buttons are enabled on the program window. The other buttons will be enabled as you advance through the program.

5. Click on the Find Server button. The program

scans for all VXI-11 Services connected to the local LAN or to your PC. (The 9006 is an RPC server which provide a VXI-11 Service) The results are displayed in the Results box.

6. When the servers(s) have been found, use the pulldown arrow in the Found Servers box to view the Found Server addresses. The board's default address is 192.168.1.254. Highlight the board's IP address and click the Create Link button. If the server is not found, you can enter the default IP address (192.168.1.254) in the Found Servers box. Click the Create Link button.

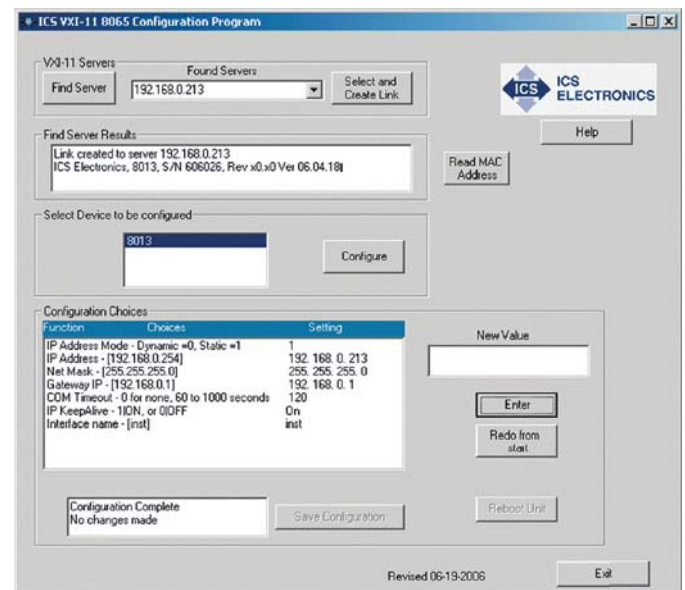

Figure 4-8 VXI-11 Configuration Utility (Showing all configuration choices with no changes)

7. When the link has been created, device model number(s) will appear in the 'Select Device to be Configured' box. Highlight the desired model number and click the Configure button to start the configuration process.

8. The Configuration Choices box displays only one line with the first parameter to be changed and its current setting. If you like the current setting, click Enter to advance to the next

parameter. If you want to change the setting, type a new value in the New Value box and click Enter. The program will send your setting to the board and read back the new setting. Repeat as needed to make another change or click Enter again to advance to the next parameter.

9. Repeat step 8 for each configuration parameter. Figure 4-8 shows the VXI-11 Configuration Utility after all parameters have been entered for a Model 9006. Click the Redo From Start button if you need to start over or if you want to change any of the prior settings

10. When done, the Save Configuration button is enabled if you changed any settings. Click the Save Configuration button to save the values in the board’s flash memory. If you did not make any changes you can just exit the program.

11. The board has to be power cycled or rebooted before the configuration changes take affect. Click the Reboot button to reboot the board and use the new settings.

12. Press the Exit button to quit the VXI11\_config program.

13. If the IP address was changed to an address outside the 192.168.1.xxx range in step 3, your PC’s network settings will have to be changed to communicate with the board. Exit the VXI11\_config program and restore the PC’s network settings.

### 5.7 Resetting Default Network Settings

The board can be reset to the default network settings listed in Table 4-2 at any time by holding the LAN Reset Button in for 5 seconds while applying power to the board. Access to this button is on the rear panel of the PRS-300..

The Digital I/O configuration values are not affected by the LAN Reset operation.

Command	Function	Factory Setting
IP Mode	Static or DHCP Mode	Static
IP Address	0.0.0.0 to 255.255.255.255.0	192.168.0.2
Net Mask	0.0.0.0 to 255.255.255.255.0	255.255.255.0
COMM Timeout	Sets socket timeout	120 sec.
Auto Disconnect	Aborts socket if link count goes to 0	Off

Table 4-2 Default Settings

### 5.8 PRS Programming

A PRS SCPI command reference is included in Appendix A. This gives a complete set of commands.

An example of commands to be sent to place the PRS in remote, this must be done first otherwise the will be no remote control of output impedance, and then configure the unit for a specific impedance value.

Where the command string is constructed as described in Appendix A and Appendix B.

A command string might be, for example:

**SOURCE:DATA 100000.1**

## Chapter 6

# IEEE INTERFACE OPTION

### 6.1 Introduction

The IEEE interface option makes the PRS-300 a IEEE-488.2-1987 and SCPI 1994.0 compatible instrument. The PRS-300 IEEE-488 interface is based upon the ICS Ethernet/GPIB/USB to Serial Interface Card. More information can be found at [www.icselect.com](http://www.icselect.com) on the 9006 Ethernet/GPIB/USB to Serial Interface Card.

The IEEE STD 488.2 covers the electrical and mechanical bus specifications, and state diagrams for each GPIB bus function. It also establishes data formats, common commands for each 488.2 device and controller protocols. The standard is available on-line at <http://www.ieee.org>.

The SCPI standard provides a tree like series of standard commands for programmable instruments so that similar instruments by different manufacturers can be controlled by the same program. SCPI information and a command reference are located in Appendix A.

Other tutorials are available on-line; consult IET for additional information. A software GPIB “keyboard” can be found at [www.ietlabs.com](http://www.ietlabs.com)

### 6.2 Capabilities

The IEEE option provides remote control over all functions except **POWER**. The IEEE option responds to all Basic Commands in Appendix B and all IEEE.2 Mandated common commands in Appendix A.

### 6.3 Address Switch and Communications Settings

The default GPIB address is 4. This address can be changed remotely by sending the command `SYSTEM:ADDR <n>` where n is 0 - 30.

### 6.4 GPIB Test Keyboard

To aid the user in operating the PRS, a GPIB “Keyboard” Controller program - the easiest way to control GPIB devices without writing a program - is available from IET. This GPIB Keyboard program automatically finds your device at start-up and it lets you enter just the data that you want to send to the device. This program works with ICS, Measurement Computing and National Instruments controllers.

To implement, request a download of **ICS\_GPIBkybd\_Install.zip** from IET Labs Tech Support.

Unzip the file and follow instructions to install.

Open the application. You may use the **Find Listeners** button to confirm that the PRS unit is recognized. Other instruments may also be recognized at this time.



# Chapter 7

## PROGRAMMING

### 7.1 Program Commands

#### 7.1.1 Calibration Interval

The standard USB interface can be programmed via any of the commands listed in Appendix B.

For USB and RS-232 interfaces, <lf>, <cr> or <crlf>, can be used as terminator. The device returns in this case <crlf>. The device performs all commands previously sent after it receives a terminator.

The optional Ethernet/IEEE/USB card can be programmed via any of the commands listed in Appendix A and Appendix B.



## Chapter 8

# MAINTENANCE

### 8.1 Verification of Performance

#### 8.1.1 Calibration Interval

The PRS Series instruments should be verified for performance at a calibration interval of twelve (12) months. This procedure may be carried out by the user, if a calibration capability is available, by IET Labs, or by a certified calibration laboratory. If the user should choose to perform this procedure, then the considerations below should be observed.

#### 8.1.2 General Considerations

It is important, whenever testing the PRS Series Decade units, to be very aware of the capabilities and limitations of the test instruments used. Such instruments have to be significantly more accurate than the specified accuracy for all applicable ranges in order to perform this task, allowing for a band of uncertainty of the instrument itself, the test setup and the environment; consult IET Labs for information.

It is important to allow both the testing instrument and the PRS-300 to stabilize for a number of hours at the nominal operating temperature of 23°C, and at nominal laboratory conditions of humidity. There should be no temperature gradients across the unit under test.

In the case of the PRS-300 a Kelvin type 4-wire test terminals should be used to obtain accurate low-resistance readings.

Steps should be taken to minimize thermal-emf effects, by maintaining an even temperature and by using only low-emf connectors. Use of meters with a “True Ohm” function is recommended.

Proper metrology practices should be followed in performing this verification.

#### 8.1.3 Calibration Procedure

1. A DMM is used to measure the resistance of the PRS-300. The DMM should have a measurement accuracy significantly more accurate than the  $\pm(70 \text{ ppm} + 1 \text{ m}\Omega)$  for all resistance values.
2. Determine the allowable upper and lower limits for each resistance setting as would be done for a decade box from 0.1  $\Omega$  to 20 M $\Omega$ s based on the specified accuracy of the PRS-300.
3. Confirm that the resistances fall within these limits
4. If any resistances fall outside these limits, See section 8.1.3 Adjustment of internal resistors.

#### 8.1.4 Adjustment of Internal Resistors

During the adjustment process a DMM such as the Fluke 8508A or Keysight 3458A using 7 ½ digits of resolution or better is connected to the binding posts of the PRS-300 using a 4 terminal Kelvin connection.

The gold shorting links must be removed on the binding posts of the PRS-300.

The PRS-300 consists 43 internal resistors which are combined in either series or parallel to achieve the programmed resistance. The gold shorting links must be removed on the binding posts of the PRS-300.

These resistors require periodic measurement to keep the PRS-300 within published specifications. The resistors are measured using a DMM. The measured value is then stored in a table within the memory of the PRS-300. The measured values of the resistors are used in an algorithm to determine which resistors are used to create the programmed resistance value.

In addition to the 43 resistors the residual internal lead resistance is also measured at time of manufacture and entered into memory. The internal lead resistance does not need to be measured again unless repair has been performed to the PRS-300.

Below is a list of the 43 resistors and their nominal resistance value. These resistors should be within  $\pm 1\%$  of the nominal value for R1 to R5 and  $\pm 0.1\%$  of the nominal value for R6 and higher to ensure proper operation of the PRS-300. If the measured value of the resistor is outside of these specifications service is required.

Resistance Number	Nominal Resistance Value
R1	0.17 $\Omega$
R2	0.35 $\Omega$
R3	0.7 $\Omega$
R4	1.37 $\Omega$
R5	2.66 $\Omega$
R6	5.15 $\Omega$

R7	10.2 $\Omega$
R8	20.0 $\Omega$
R9	38.8 $\Omega$
R10	75.6 $\Omega$
R11	148.0 $\Omega$
R12	287.0 $\Omega$
R13	570.0 $\Omega$
R14	1.13 k $\Omega$
R15	2.23 k $\Omega$
R16	4.4 k $\Omega$
R17	8.7 k $\Omega$
R18	17.0 k $\Omega$
R19	33.3 k $\Omega$
R20	66.0 k $\Omega$
R21	130.0 k $\Omega$
R22	258.0 k $\Omega$
R23	506.0 k $\Omega$
R24	1.0 M $\Omega$
R25	2.0 M $\Omega$
R26	3.99 M $\Omega$
R27	7.8 M $\Omega$
R28	15.0 M $\Omega$
R29	30.0 M $\Omega$
R30	60.0 M $\Omega$
R31	120.0 M $\Omega$
R32	3.55 k $\Omega$
R33	7.39 k $\Omega$
R34	16.4 k $\Omega$
R35	33.8 k $\Omega$
R36	72.2 k $\Omega$
R37	147.0 k $\Omega$
R38	300.0 k $\Omega$
R39	600.0 k $\Omega$
R40	1.23 M $\Omega$
R41	2.48 M $\Omega$
R42	5.0 M $\Omega$
R43	10.0 M $\Omega$

During the adjustment process the firmware cycles through each resistor and the technician can enter the measured resistance value in ohms. This should be done with a minimum of 7 ½ digits of resolution. The accuracy of measurement should be significantly more accurate than the  $\pm(70 \text{ ppm} + 1 \text{ m}\Omega)$  for all resistance values.

To enter into the calibration process, press the MENU key and then select 3 for calibration. At the end of the process all calibration values will be saved into memory.

At anytime pressing the MENU key will exit calibration without making any changes.

IET Labs uses the Fluke 8508A, set to 7 ½ digits of resolution, during the adjustment process to ensure the PRS-300 meets specifications.

IET Labs offers the PRS-DMM software which works with the PRS-300 and Fluke 8508A or Keysight 3458A to automate this adjustment process. See Chapter 9.

# Chapter 9

## PRS-DMM Self Adjusting Software

### 9.1 PRS-DMM Self Adjusting Software

#### 9.1.1 Overview

The PRS-DMM Self Adjusting Software is a Windows based software package using LabVIEW 2013 RTE.

The software is designed to be used with the PRS-300 Programmable Resistance Substituter and the Keysight 3458A or Fluke 8508A DMMs.

The DMM is used to measure the resistance of the PRS-300, and then the software adjusts the output resistance of the PRS-300 to achieve the closest possible resistance value to the target resistance value.

This can improve the accuracy of the PRS-300 from  $\pm(70 \text{ ppm} + 1 \text{ m}\Omega)$  to better than  $\pm 10$  ppm short-term without switching.

#### 9.1.2 General Requirements

The PRS-DMM Self Adjusting Software does require:

- Windows 8 or Windows 10 PC
- National Instruments GPIB-USB-HS or equivalent GPIB interface
- Fluke 8508A DMM or Keysight 3458A DMM
- PRS-300 Programmable Resistance Substituter
- Kelvin cables between PRS-300 and

Fluke 8508A

- GPIB cables as necessary

#### 9.1.3 Software Installation

Install the PRS-DMM Self Adjusting Software using the supplied USB stick. This will install the PRS-DMM software as well as the LabVIEW 2013 RTE. This software is also available at <http://www.ietlabs.com/prs-dmm.html>

If using the PRS-300 with standard USB interface, the FTDI driver should also be installed. These can be download at <http://www.ietlabs.com/Drivers/FTDI.zip>

#### 9.1.4 Connection between DMM and PRS-300

Connect the PRS-300 to the DMM using good quality low thermal EMF cables using a 4 terminal kelvin connection.

If the end use of the PRS-300 will be 2 Wire then keep shorting links installed. In the menu of the PRS-300 it should be configured for “2W” Mode.

If the end use of the PRS-300 will be 4 wire then remove shorting links. In the menu of the PRS-300 it should be configured for “4W” mode.

See section 3.4.10 for more information on 2-wire and 4-wire connections.

#### 9.1.5 Connections of PRS and DMM

Connect the 3458A or 8508A DMM to the

PC via GPIB. Connect the PRS-300 to the PC via GPIB or USB. Make sure the addresses are different on DMM and PRS-300.

### 9.2 PRS-DMM Main Screen

The main screen of the PRS-DMM software is shown below.

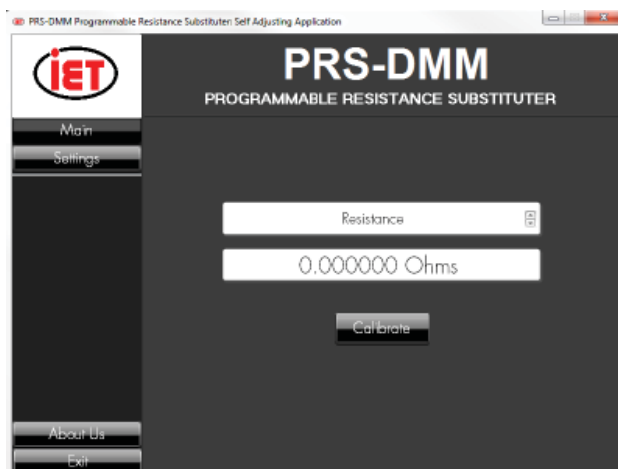

Figure 9.1 PRS-DMM Main Screen

There are 4 buttons; Main, Settings, About Us and Exit.

#### 9.2.1 PRS-DMM Main Screen Operation

The main screen of the PRS-DMM allows the user to select Resistance or RTD tables, and it also allows to be entered the target resistance value or temperature.

Assuming that the PRS-300 is connected to the PC and turned on, any value entered as a target value will automatically switch the PRS-300 to that resistance or resistance equivalent to the entered temperature value.

Clicking on the Calibrate button starts the process of adjusting. The DMM Measures and adjusts the PRS-300 to achieve the closest value possible to the entered target value. The accuracy depends upon the MEASUREMENT

SPEED. See section 9.3.5.

### 9.3 PRS-DMM Settings

#### 9.3.1 PRS-DMM Settings Screen

The Settings screen is shown in Figure 9.2. This menu should be configured first to set address of the PRS-300 and DMM.

This menu also allows for adjustment of the PRS-300 which automates the adjustment process of the PRS-300 as described in section 8.4.1.

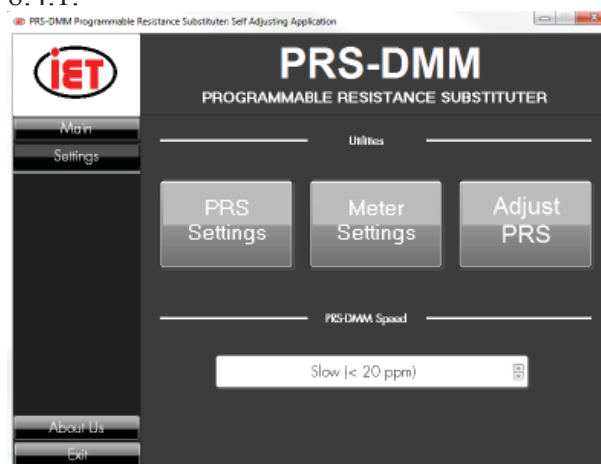

Figure 9.2 PRS-DMM Settings Screen

#### 9.3.2 PRS Settings

PRS Setting screen allows the operator to select the COM port or GPIB address of the PRS-300. Make sure the PRS-300 and DMM are turned on and connected to the PC.

If the address or COM port of the PRS-300 or DMM is not shown in the I/O box then click on refresh. Select the GPIB address or COM port and then click the Initialize button. The IDN string will be shown in the white box along with a Success indication.

Click Exit button to return to Setting Screen once PRS has been detected.



**Figure 9.3 PRS Settings Screen**

### 9.3.3 Meter Settings

Meter Setting screen allows the operator to select which DMM will be used either the Fluke 8508A or the Keysight 3458A. The GPIB address of the DMM can also be set in this menu. Make sure the DMM is turned on and connected to the PC.



**Figure 9.4 Meter Screen**

Select the GPIB address and then click the Initialize button. The IDN string will be shown in the white box along with a Success indication.

The PRS-DMM software will configure the DMM for resistance measurements, appro-

appropriate resolution 7 ½ digits for slow, 6 ½ digits for medium and fast, 4 wire measurements and autorange ON.

The 8508A will also be configured for Low Current, Fast AD Integration OFF, and Analog Filter OFF.

If additional commands need to be sent to the DMM, click on the Configure Button and enter the commands in the text box.

Once the commands have been entered press the Configure button. Any commands will be sent to the DMM during initialization of the DMM.

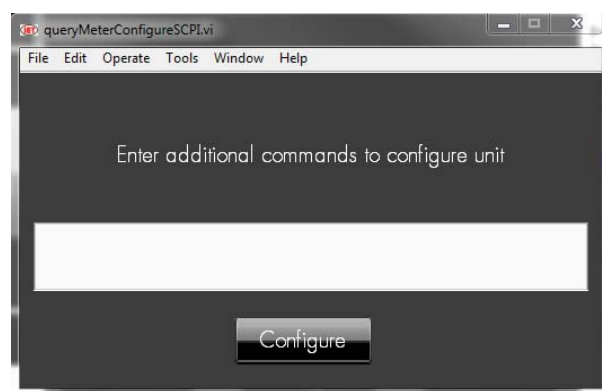

**Figure 9.5 Meter Configure Screen**

Click Exit button to return to Setting Screen once DMM has been detected.

### 9.3.4 Adjust PRS

Clicking on the Adjust PRS button will step the operator through the PRS-300 adjustment procedure. The procedure consists of measuring all 43 internal resistors using the DMM and storing the actual resistance values into a table. These resistance values are used in the algorithm to create the programmed resistance value. See section 8.1.4 for more information.



### 9.3.5 PRS-DMM Speed

There are three selections for PRS-DMM Speed. These selection affect the accuracy from the target value and time to make the measurements.

Slow measurements are made with 7 ½ digits of resolution, and measurements and adjustments are made until the accuracy is better than ±20 ppm.

Medium measurements are made with 6 ½ digits of resolution and measurements and adjustments are made until the accuracy is better than 40 ppm.

Fast measurements are made with 6 ½ digits of resolution. There are no adjustments made in fast mode. The value from the DMM is just displayed.

The uncertainty of the measurement is also displayed. The uncertainty is based upon the specifications given in the manual for the Fluke 8508A or Agilent 3458A. The uncertainty is based upon either 6 ½ or 7 ½ digits of resolution, absolute uncertainty for 365 days and a 95% confidence level.



## Appendix A

# SCPI COMMAND REFERENCE

SCPI is an acronym for “Standard Commands for Programmable Instruments”. For additional information or an on-line copy of this standard, see:

<http://www.scpiconsortium.org>.

The IEEE 488.2 Standard was established in 1987 to standardize message protocols and status reporting and to define a set of common commands for use on the IEEE 488 bus. IEEE 488.2 devices are supposed to receive messages in a more flexible manner than they send. A message sent from GPIB controller to GPIB device is called: PROGRAM MESSAGE. A message sent from device to controller is called: RESPONSE MESSAGE. As part of the protocol standardization the following rules were generated:

- (;) Semicolons separate messages.
- (:) Colons separate command words.
- (,) Commas separate data fields.
- <nl> Line feed and/or EOI as last

character

terminates a ‘program message’.

Line feed (ASCII 10) and EOI terminates a RESPONSE MESSAGE.

(\*) Asterisk defines a IEEE 488.2 common command.

(?) Ends a query where a reply is expected.

SCPI builds on the programming syntax of IEEE-488.2 to give the programmer the capability of handling a wide variety of instrument functions in a common manner. This gives all instruments a common “look and feel”. SCPI commands are not case-sensitive.

The portion of commands shown in capitals denotes the abbreviated form of the keyword. Either the abbreviated or whole keyword may be used when entering a complete command. There must be a space between the command and a parameter or channel list. Multiple SCPI commands may be concatenated together as a compound command by using semicolons as command separators.

Keywords shown inside braces [ ] are defaults, and are optional when constructing a PROGRAM MESSAGE.

Terminators: For GPIB interface each command line must end with line feed <lf>. Response from the device also returns line feed <lf>.

Commands not recognized have no effect on the unit's operation and will set the corresponding bits in the Standard Event Status Register. SCPI commands that end with a question mark '?' are queries. All queries should be followed by reading their response to avoid data loss.

Semicolon ';' is used to separate more commands written on one line.

**IEEE-488.2 Common Commands**

\*IDN?

Returns instrument identification "IET Labs,PRS-300,<Serial Number>,<software version>"

\*ESR?

Returns the read of the event status register.

\*STB?

Returns the read of the status byte register.

\*ESE?

Returns the read of the event status enable register.

\*SRE?

Returns the read of the service request enable register.

\*ESE

Set the event status enable register value

\*SRE

Set the service request enable register value

\*RST

Reset the buffer

\*TST?

Self test query

\*CLS

Clear standard event status register

\*OPC

Operation complete

\*OPC?

Operation complete query

\*WAIT

Wait until operation is complete before executing next command(No Function in PRS)

\*PCS

Power-on Status Clear

Note: Remote command can start with or without \* symbol for compatibility.

2.13 Formats

IEEE 488.2 enables remote programming of all instrument functions, measurement conditions and comparator settings etc. Outputs include measurement conditions, open/short corrections, and measured values.

Data Formats

Data will be transmitted in ASCII NR3 format per IEEE488.2 sec. 8.7.4 and reproduced below. Note that there is always precisely one digit before the decimal point, and precisely three digits in the exponent.

Multiple results

For the case where a measurement produces multiple results (e.g. MEASure Cs, and DF), the individual numbers will be separated by commas per IEEE488.2 para. 8.4.2.2.

Sequences of Test (Sequence Mode) will be treated as a single Message Unit, with results separated by commas. If a particular test has “None” selected as a secondary parameter, no place will be reserved for the null result. As an example, a sequence of three tests asking for C/D, ESR, and Z/□ would appear as follows:

<data>,<data>,<data>,<data>,<data><NL>

All response messages will be terminated by the NL character together with the EOI line asserted.

Status Byte Register

Bit	Decimal Value	Use
7	128	None
6	64	SRQ, SPOL Resets
5	32	Summary of Standard Event Status Register*
4	16	Message Available
3	8	None
2	4	None
1	2	None
0	1	None

\*The Status Byte Register is readable via the standard STB? as defined in para. 11.2.2.2 of the IEEE spec. The 7600 Plus will also implement an SRE register to enable each bit of the Status Byte Register per para 11.3.2 of the IEEE spec. This register shall be readable by a SRE? command and writeable by a SRE <#> command.

Standard Event Status Register

Bit	Decimal Value	Use
7	128	Power Up Since Last Query

6	64	None
5	32	Command Error (Syntax)
4	16	Execution Error (Over Range, etc.)
3	8	No Contact
2	4	Query Error
1	2	None
0	1	Operation Complete

This register is read by executing an “ESR?” command, page 76 (except no \*). Note that this is a destructive read. Reading the register clears it. Each bit of the Event register must be enabled in order to cause the ESB bit of the Status Register to be set. This enabling is done in the Standard Event Status Enable Register by issuing an ESE command.

## Appendix B

### PRS-300 USB and COMMON COMMANDS

#### COMMON Commands:

- \*IDN? Returns instrument identification “IET Labs Inc.,PRS-300,<Serial number>,<software version>”  
Serial number in the form “Ax-xxxxxxx” x = 0 to 9. A = Alpha can be A to Z.
- \*TST? Self-Test Returns ASCII 0 or 1, 0 = bad or 1 = good
- \*RST Returns PRS-300 to default “power on” condition
- \*SAV <number> Saves current resistance value into memory location 0 to 9  
Number is 0 to 9
- \*RCL< number> Recalls resistance value from memory location 0 to 9  
Number is 0 to 9

#### SYSTEM Commands

SYSTEM:SERIAL <Ax-xxxxxxx> Sets the serial number in non-volatile memory < serial number>  
Serial number in the form “Ax-xxxxxxx” x = 0 to 9. A = Alpha can be A to Z.

SYSTEM:SERIAL? Returns Serial number

SYSTEM:CONTRAST <number> Sets system contrast specific number from 0 to 15

SYSTEM:KEY <number> Same as pressing button on front panel of PRS-300  
<Number> is 0 to 24

keys 0-9	0 – 9
A, B, ▲, ▼	10 – 13
OPEN	14
MENU	15
TABLE	16
RCL, SAV	17 – 18
VOLT	19
INCR	20
Decimal Point	21
000 / (-)	22
BACK	23
ENTER	24

**SYSTem:LOCal:** This command places device in the LOCAL mode and unlocks all keys on front panel of the device. The Command is valid only for RS232, and USB interfaces.

**SYSTem:REMOte** This command places device in the REMOTE mode and locks all keys. The Command is valid only for RS232, and USB interfaces.

### **CALIBRATION Commands**

**CALibrate:RESistance** Goes into calibration mode starting at resistor 1 and then progressing to resistor 43. Each time the command CALI:RES:SET is used the resistor number is automatically incremented by 1.

**CALibrate:RESistance?** Returns resistance number to be calibrated.  
Numbers 1 to 43

**CALibrate:RESistance:SET <number>** Sets calibrated value of resistance in ohms into memory. <number> is a floating point number representing the resistance value in ohms for the internal resistor being measured. Each time the command CALI:RES:SET is used the resistor number is automatically incremented by 1.

**CALibrate:RESistance:SET?** Returns the calibrated value of resistance in ohms

**CALibrate:DATE <mmddyyyy>** Sets calibration date into memory

**CALibrate:DATE?** Returns calibration date in format mmddyyyy

### **SOURCE Commands**

**SOURce:DATA <display value>** Sets output resistance of the PRS-300 if table is set to 0 or the resistance value corresponding to the display value for the table selected.  
Display value in form of number and decimal point representing desired display value.

example **SOURce:DATA 1.000002** would set resistance value to 1.000002  $\Omega$  if Table is set to 0.

**SOURce:DATA?** Returns display value currently shown in the PRS display



SOURce:RESistance <display value> Sets output resistance of the PRS-300 if table is set to 0 or the resistance value corresponding to the display value for the table selected.

Display value is in the form of number and decimal point representing desired display value. This is the same as SOURce:DATA command.

example SOURce:RES 0 would set display value to 0 and if Table is set to 1 to 4 this would represent the resistance value depending upon how the table is configured. If in Celsius and PT-100 then resistance of 100  $\Omega$  would be set at output of PRS-300.

### CONFIGURE Commands

CONFIGURE:SELECT <2 or 4> Sets PRS-300 for 2 wire or 4 wire mode.

CONFIGURE:SELECT ? Returns number corresponding to 2 wire or 4 wire mode. 2 = 2 wire and 4 = 4 wire

CONFigure:TABLE:SElect <number> Selects Table to be used, <number> is 0 to 4. 0 is no table with display shown in ohms and 1, 2 and 3 are user defined tables

CONFigure:TABLE:SElect? Returns table number that is selected

CONFigure:TABLE:NAME <name> Sets Table name, <name> is ASCII up to 20 characters such as "PT100"

CONFigure:TABLE:NAME? Returns the number, 1 to 4, of currently selected table

CONFigure:TABLE:ERASE Erases all rows in the table

CONFigure:TABLE:ADD <user\_value, resistance\_value> Adds a row to the end of table showing user value and resistance value in ohms.

example CONF:TABL:ADD 20, 95 means that if the table is selected and the operator enters 20 from the front panel the output will be set to 90  $\Omega$ .

CONFigure:TABLE:ADD? Returns the last entry in the table

CONFigure:TABLE:DISPlay? Returns all data in the table

Example of information returned

PT100  
20, 95

CONFigure:TABLE:UNIT <Unit> Set units for tables up to 8 ASCII characters  
As an example "C" could be send for Celsius or "F" for Fahrenheit

CONFigure:TABLE:UNIT? Returns ASCII string representing the units

CONFigure:SELECT <"2" or "4"> Sets "2" Wire or "4" Wire mode



